



VIPColor VP600 Printer Series

User Guide

Copyright © 2019 VIPColor Technologies Pte Ltd. All rights reserved.

No part of this document may be photocopied, reproduced, or translated to another language without the prior written permission of VIPColor Technologies Pte Ltd.

Trademarks

Firefox is a trademark of the Mozilla Foundation.

Intel and Intel Core are trademarks of Intel Corporation in the U.S. and/or other countries.

Java and Oracle are registered trademarks of Oracle and/or its affiliates.

Microsoft, Windows, and Windows Server are registered trademarks of Microsoft Corporation in the U.S.A. and/or other countries.

Memjet is a trademark of Memjet Ltd.

Edition

Edition 3, Oct 2019.

FCC

This device complies with Part 15 of the FCC rules. Operation is subject to the following two conditions: (1) this device may not cause harmful interference, and (2) this device must accept any interference received, including interference that may cause undesired operation.

Safety Precautions



Electrical Shock Hazard

Do not disassemble any part of your printer. There are no user-repairable parts inside the printer. Disassembly of any part of the printer will void all warranties.



Fire Hazard

Keep the printer well away from all heat sources and flammable substances.

Switch your printer off immediately and unplug the power cord from the wall socket if you notice any of the following:

- Smoke rising from the printer.
- An acrid smell coming from the printer.
- Sparks being emitted from printer.

Contact your supplier as soon as possible.



WARNING: Hazardous Moving Parts

Keep fingers and other body parts away from the printer.

Installation

- Install the printer on a flat, level surface.
The printer must remain level at all times. Tilting the printer may cause undue leakage of ink and affect performance and print quality.
- Avoid wide temperature variations.
Install the printer in a protected location away from direct sunlight, open windows or any other places subject to temperature extremes.

Power Supply

Input Rating	100–240 VAC, 50/60 Hz, 3.6 A
Operating Temperature	15°C to 35°C

- Always use the Power button on the control panel to turn the printer off.
Removing power to the printer in any other manner may damage the printer.
- Use only the supplied power cord.
Use of any other power supplies or cords may damage the printer and void your warranty.

Printer Usage

- Ensure adequate ventilation to the printer.
Blocking ventilation openings around the printer may cause it to overheat and become damaged.
- Keep liquids and heavy objects away from the printer.
Heavy objects may warp the outer shell, damaging the printer. Liquids may discolor or damage the skin and, if they penetrate it, may damage the printer beyond repair.
- Use only authorized consumables.
Use of any printhead other than authorized Memjet technology printheads will damage the printer and void your warranty. Use of unauthorized inks or ink cartridges may damage the printer and will void your warranty.
- Clear media jams promptly.
To avoid further problems, promptly attend to all media jams, as well as any other cause of printer failure.
- If you are moving the printer, allow sufficient time after installation for the temperature and humidity of the internals of the printer to arrive at equilibrium with the surroundings.

Contents

Safety Precautions	3
Using the Printer	7
Parts of the Printer	8
Using the Control Panel	9
Selecting the Security Level	11
Choosing Label Media	12
Loading Label Media	15
Loading Fanfold Media	17
Printing Labels	18
Change Default Settings in Printer Driver	18
Select the Media Type	20
Adjust Alignment for Printing	21
Printing Borderless (Full-Bleed) Labels	22
Saving Custom Media Size Settings	23
Turning Off the Printer	24
Managing Printer Security (Administrator)	25
Embedded Web Server (EWS)	27
Other Support Tools	35
Printer Maintenance	37
Guidelines for Preventive Maintenance	38
Replacing an Ink Cartridge	39
Cleaning the Printhead	40
Replacing the Printhead	41
Opening/Closing the Clamshell	44
Cleaning Debris from the Cutting Zone	45
Cleaning the Sensors	46
Replacing the Output Module/Cutter Assembly	47
Replacing the Service Station	51
Replacing the Transfer Wiper Assembly	54
Replacing the Aerosol Fan Filter	56
Replacing the Waste Ink Absorber	57
Troubleshooting	59
If Error Messages Appear	60
Poor Print Quality or Incorrect Printout	64
Other Printing Problems	67
Clearing a Media Jam	68
Clearing Clogged Ink Nozzles	68
Adjusting Sensor Sensitivity	70

Appendix	71
System Requirements	72
Additional Networking Information	74
If the Printer Has a Static IP Address	74
If the Connection to the Printer Has Changed.....	74
Config Options on the Control Panel.....	75
Printer Interface (GPIO) Specifications	79
Regulatory Information.....	81
Worldwide VIPColor Technologies Contacts.....	84

Chapter 1

Using the Printer

Parts of the Printer	8
Using the Control Panel	9
Choosing Label Media	12
Loading Label Media	15
Loading Fanfold Media	17
Printing Labels	18
Printing Borderless (Full-Bleed) Labels	22
Saving Custom Media Size Settings	23
Turning Off the Printer	24
Managing Printer Security (Administrator)	25
Embedded Web Server (EWS)	27
Other Support Tools	35

NOTE: Once the printer has been set up, be sure to change the security passwords using the Embedded Web Server (EWS). See [Change Passwords](#) on page 25.

Parts of the Printer

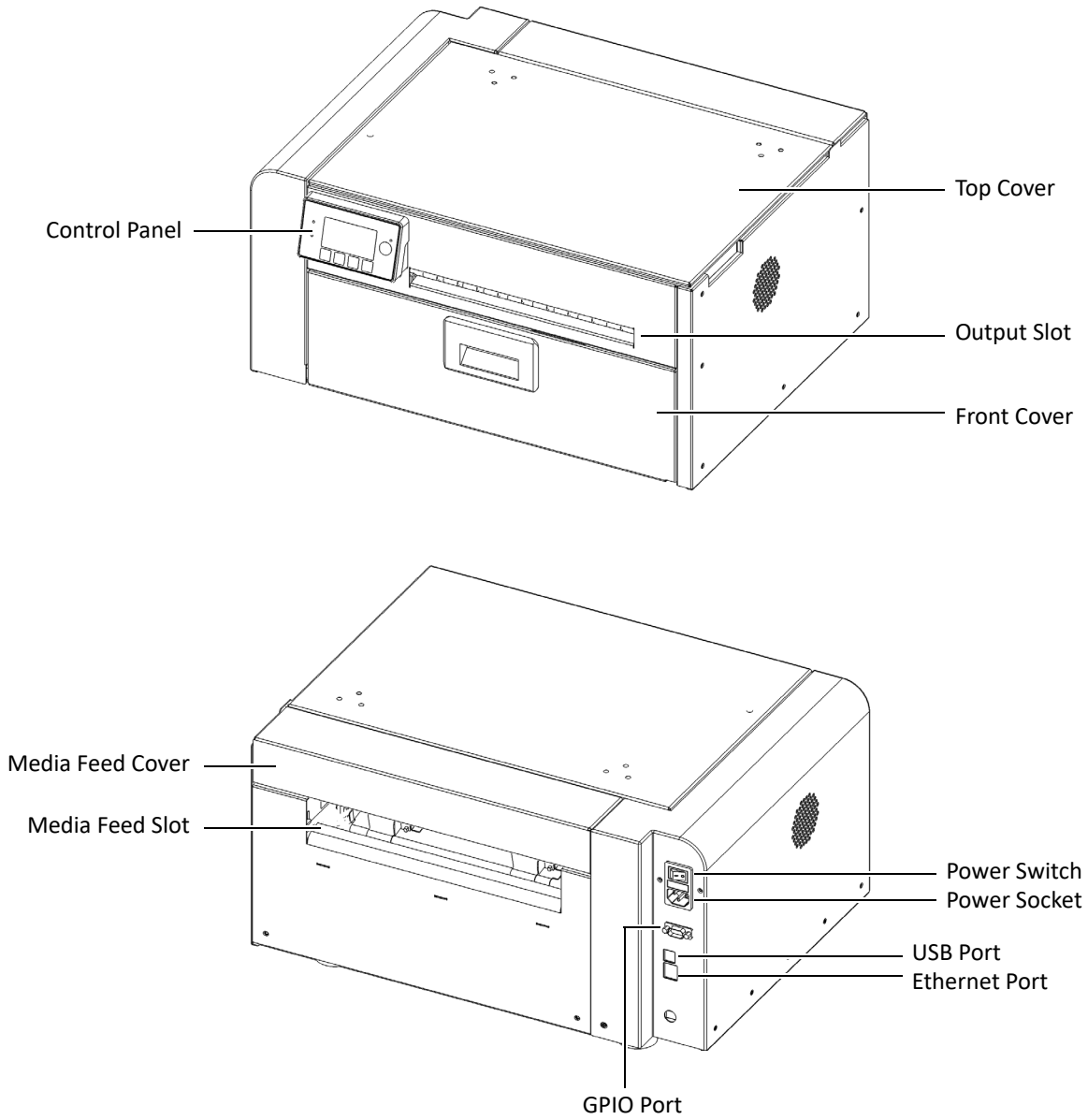

Using the Control Panel

The printer is ready to print when the control panel displays Printer Online. The Data and Status LEDs together with messages indicate the printer status and any potential problems (Table 1).

The control panel also shows the estimated levels of the ink cartridges. In the example below, the yellow ink cartridge level is between 25 to 50%.

The icons above the printer buttons indicate their functions, which change depending on the current operation (see Table 2).

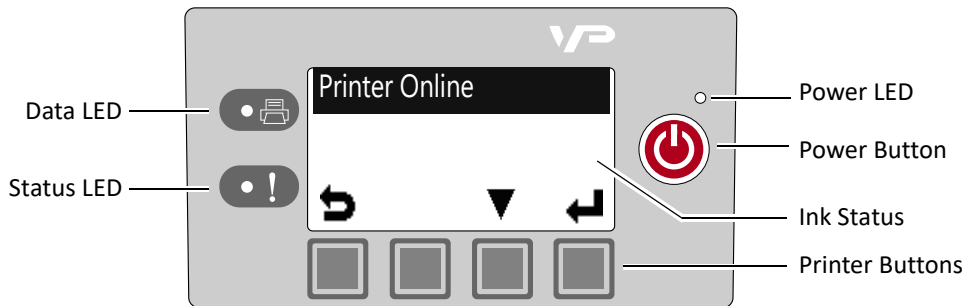







Table 1 Printer LEDs

LED	Description
Data LED	
Blinking	Printer is receiving data from the computer.
On	There are print jobs in the printer memory.
Status LED	
Blinking	<ul style="list-style-type: none"> Printhead is being serviced, or Attention needed; a message will be displayed. (See If Error Messages Appear on page 60.)
On	<ul style="list-style-type: none"> An error has occurred; a message will be displayed. (See If Error Messages Appear on page 60.)

The icons above the printer buttons indicate their functions (Table 2).

- When the printer is online, press  (Config) to access the configuration menus. The options are described in [Config Options on the Control Panel](#) on page 75.
- Press  and  to scroll through the menus.
- Press  (Select) to select an option or setting.
- Press  (Return) to return to the previous menu.

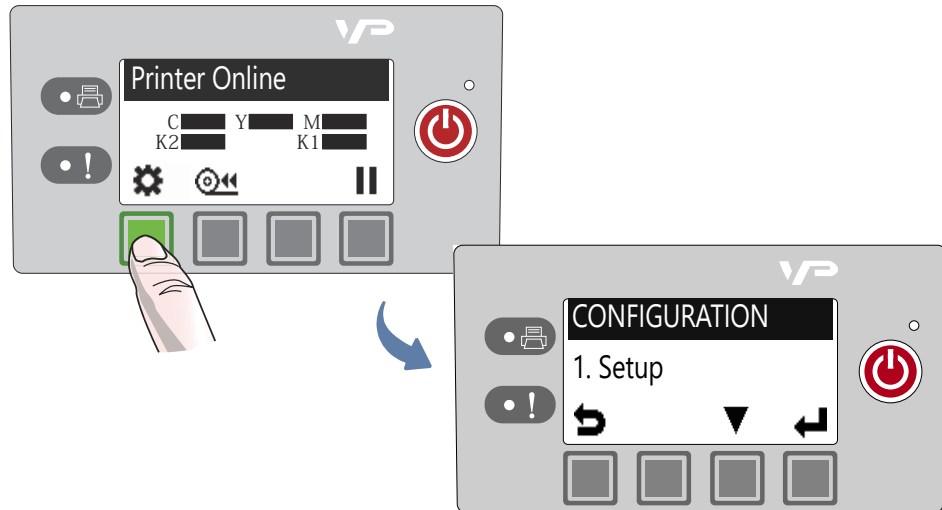











Table 2 Printer Buttons

Function	Description
 Config	Access the Configuration menus.
 Up,  Down	Move through the menu options.
 Select	Select a menu option or confirm a setting.
 Return	Return to previous menu.
 Unload Media	Unload the labels.
 Pause,  Resume	Pause or resume printing. If printing Roll to Roll, the printer pauses for 10 seconds, then prints the next page and pauses again. It will continue to print and pause.
 Cancel	Cancel printing.

Selecting the Security Level

By default, the printer powers up in security Level 0 (operator), which does not allow changes to some printer parameters. To make changes, select security Level 1 (supervisor) and enter the password provided by your administrator.

Security Level 2 gives administrator access to all functions.

1. On the control panel, select  (Config) → SETUP → SECURITY → Level 1 or Level 2.
2. Enter the 3-digit password.

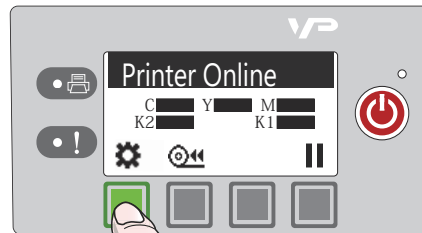

(Config)

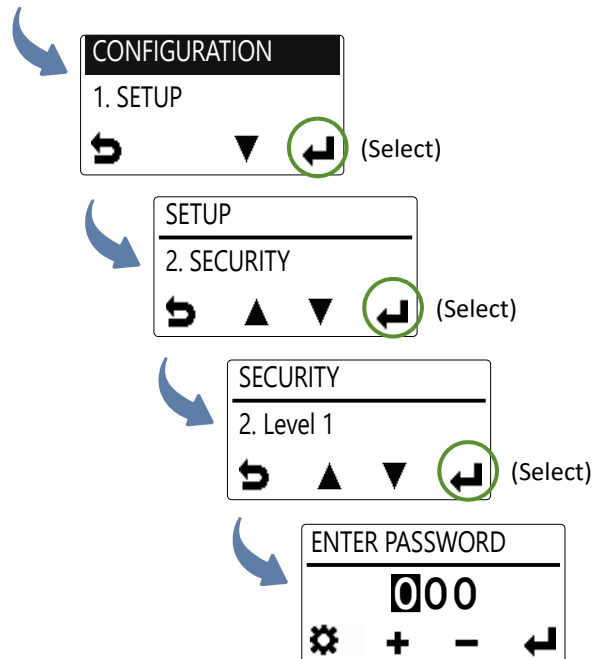

3. Press  to return to the main menu.

Choosing Label Media

Ensure that the label media meets the requirements for the printer (see [Table 3](#) and the following illustrations). Always test the media first to see if it meets your expectations. To check the compatibility of label media, print the barcodes test page.

Table 3 Media specifications

Media Type and Dimensions	
Media type	Gloss, semi-gloss, and matte.
Label width	2.0" to 8.5" (50.8 mm to 215.9 mm)
Label length	Continuous/Roll to Roll: Maximum 48" (1.219 m) Roll to Cut/Print and Present: Maximum 48" (1.219 m)
Label thickness	Maximum 0.01" (0.3 mm) (including liner, if any) Minimum 0.005" (0.13 mm)
Core size	3" (76.2 mm)
Roll diameter	Maximum 6" (152.4 mm)
Media Handling	
Print mode	<ul style="list-style-type: none"> • Roll to Cut • Print and Present (non-peel) • Roll to Roll
Detection	<ul style="list-style-type: none"> • Gap • Continuous • Black mark

Figure 1 Media Roll

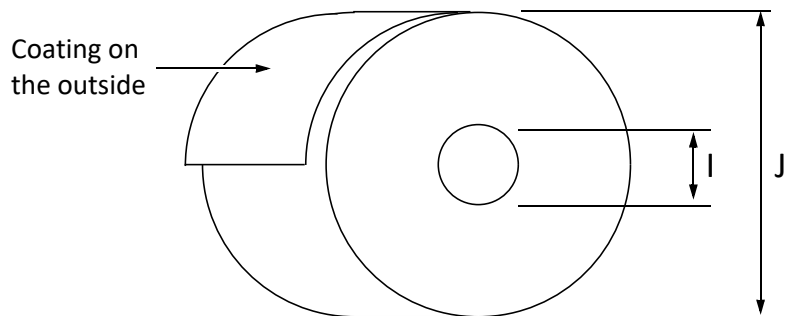

	Minimum	Maximum
I	3.0" (76.0 mm) cardboard core	3.0" (76.0 mm) cardboard core
J	N/A	Up to 6" (152.4 mm)

Figure 2 Gap (Transmissive) Media

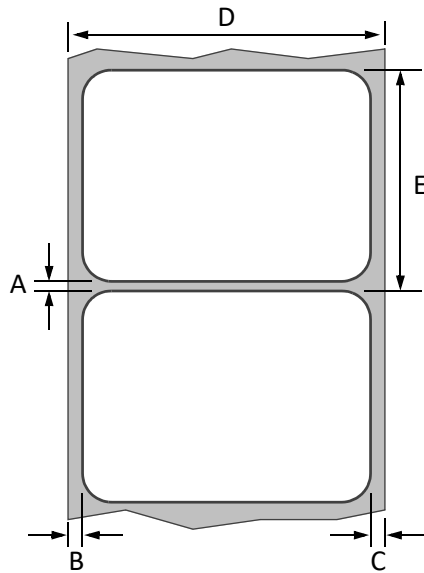

	Minimum	Maximum
A	0.125" (3.0 mm)	0.3" (8.0 mm)
B	0.0	2.0" (50.8 mm)
C	0.0	0.4" (10mm)
D	2.0" (50.8 mm)	8.5" (216.0 mm)
E	2.0" (50.8 mm)	40.0" (1016.0 mm)

Figure 3 Black Mark (Reflective) Media

Reverse side of tag stock

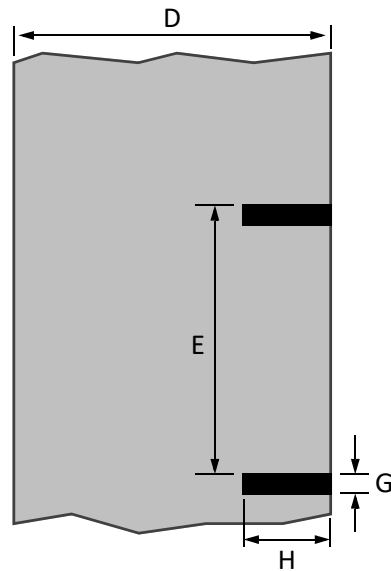

	Minimum	Maximum
D	2.0" (50.8 mm)	8.5" (216.0 mm)
E	2.0" (50.8 mm)	40.0" (1016.0 mm)
H	1.0" (25.4 mm)	8.5" (216.0 mm)
G	0.125" (3.0 mm)	0.3" (8.0 mm)

Print Test Page

Load 4" x 4" or larger labels. Be sure to select the label type (continuous, gap, or black mark) in the EWS Diagnostics page.

1. On the control panel, select  (Config) → MAINTENANCE → PRINT TEST PAGE → Barcodes.

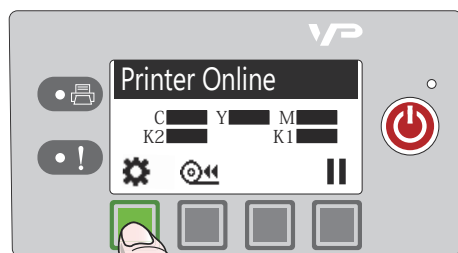

(Config)

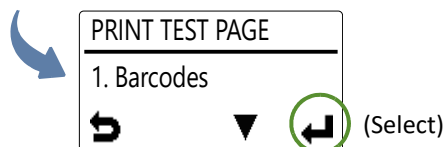
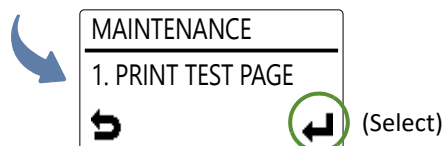
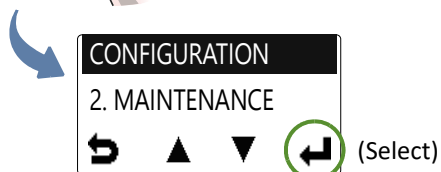

Sample Barcodes Test Page

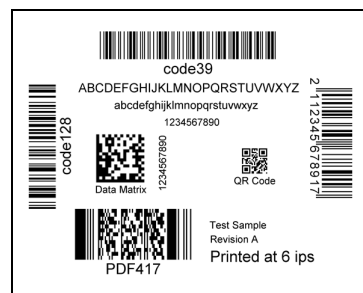

2. Verify the following on the test page:
 - Label is printed in black with no other color visible.
 - The text is legible.
 - The barcodes are readable.
 - No ink smear, color mix or streaks.

Loading Label Media

Figure 4 Media path

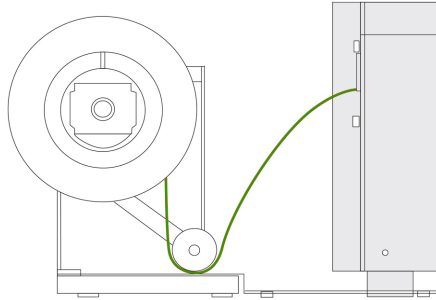

1. Loosen the knob and remove the roll cover.

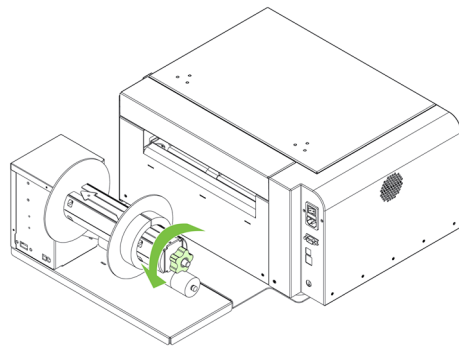

2. Load the media roll.

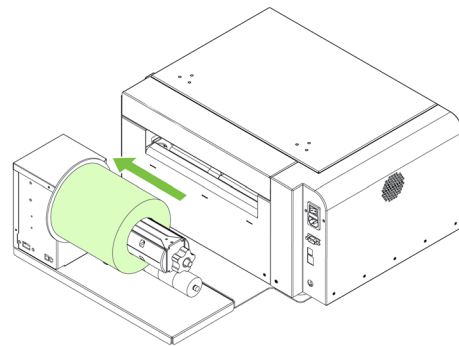

3. Push the roll cover against the media roll. Make sure the slot in the roll cover is over the flat side of the spindle. Then tighten the knob.

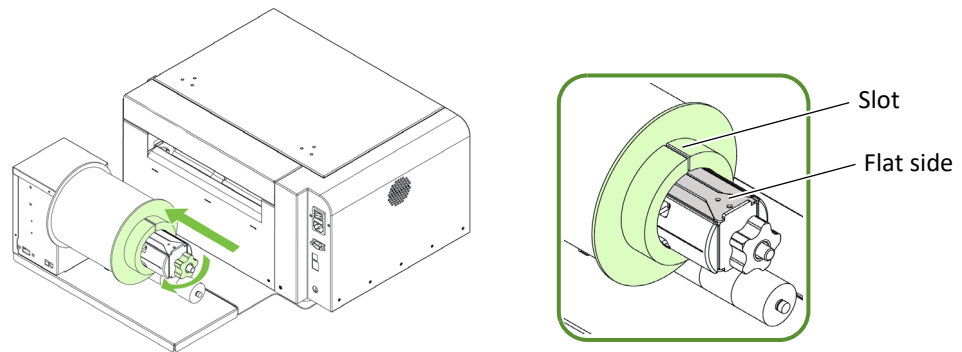

4. Feed the media into the printer:
 - a Open the media feed cover.
 - b Feed the media under the arm and into the printer. Wait for the printer to load the media.
 - c Slide the media guide to the edge of the media.

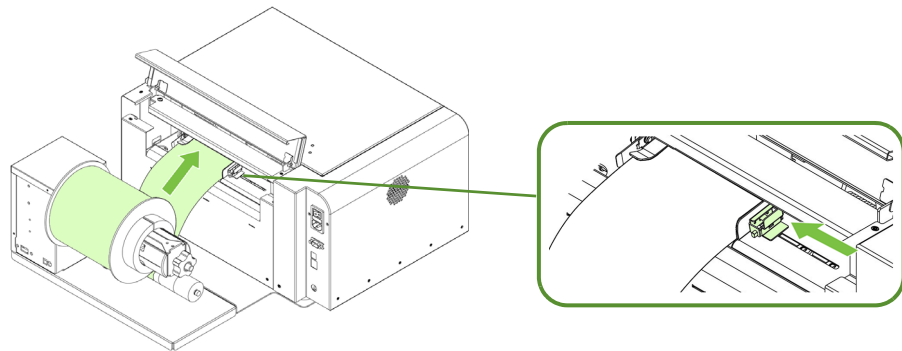

5. Close the media feed cover.

Loading Fanfold Media

Figure 5 Fanfold media path

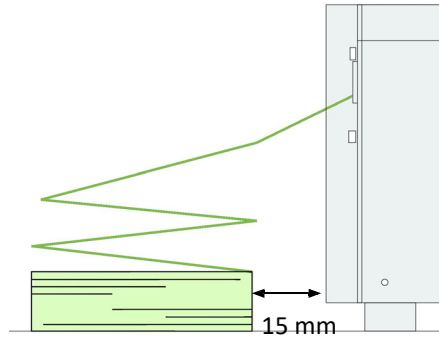

1. When loading fanfold media, place the media stack 15 mm or more away from the rear of the printer.
2. Feed the media into the printer, aligning it with the left side of the media feed slot. Wait for the printer to load the media.
3. Slide the media guide to the edge of the media.

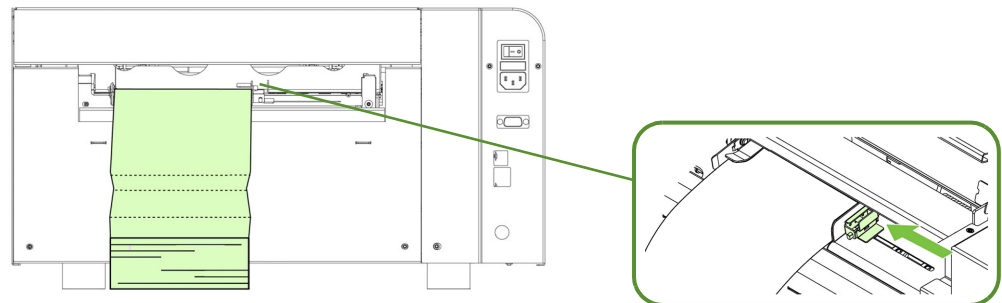

Printing Labels

The printer is ready to print when the control panel displays Printer Online.

1. Select the **Print** command from your application.
2. Select the printer and click the **Setup, Properties** or similar button.

The print settings displayed are the defaults that were set in the printer driver.

3. Change the print settings if needed.

NOTE: Ensure the media settings (e.g. label size) match the media loaded in the printer.

4. Print the document.

Any changes to the settings only apply to the current print job. Once you exit the application, the changes may be lost. Make the changes in the printer driver if you wish to keep the settings as the default for all print jobs.

Change Default Settings in Printer Driver

To select the default print settings that will be used for all print jobs:

1. From the Windows **Start** menu, select **Devices and Printers**¹.
2. Right-click the printer, and select **Printing preferences**.
3. Make the changes (see [Figure 6](#)) and click **OK** to save.

1. For Windows 7. The steps will differ for other Windows versions.

Figure 6 Printing Preferences

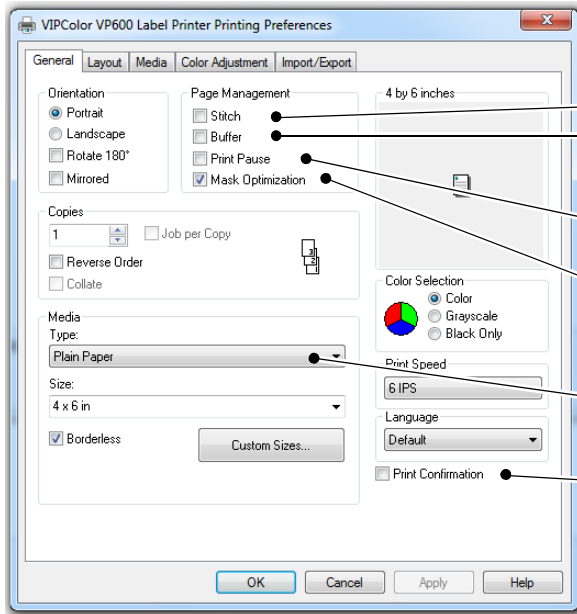

Print pages without any gap (continuous media only)

Render entire document to disk before sending to the printer. Select this option if labels are skipped when printing large files.

Select this option if labels are skipped when printing small labels.

Select this option to remove print artifacts with image file with multiple layers.

Select the Media Type that matches the media loaded in the printer.

Display a print confirmation message before printing.

Adjust horizontal and vertical print position.
See [Adjust Alignment for Printing](#).

Use the settings on the printer control panel.

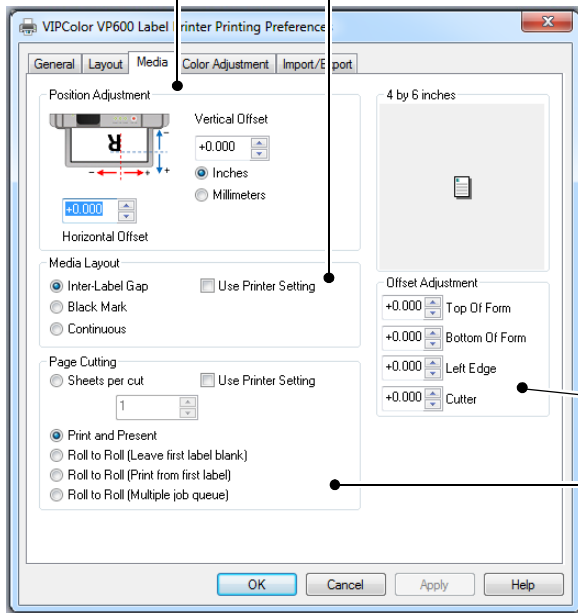
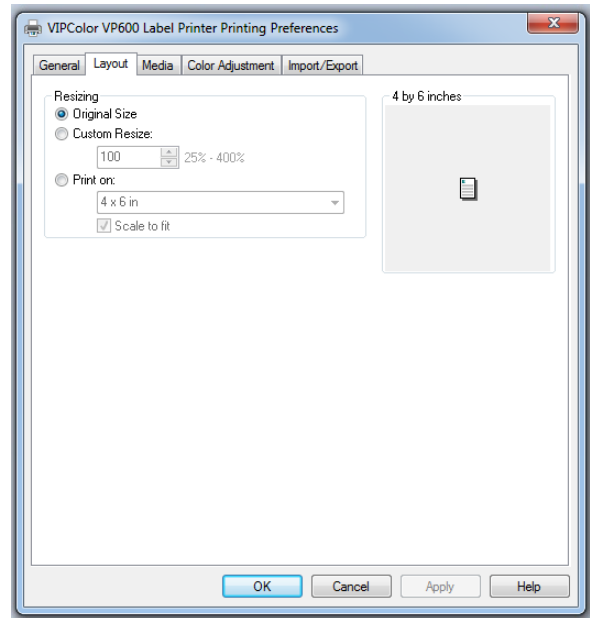

Adjust the various offsets

Sheets per cut – Cut after printing the specified number of labels.

Print and Present – Print, cut, and present label. Remove the label to continue printing.

Roll to Roll – Select Roll to Roll if a rewinder is used. Choose whether to print the first label or print multiple jobs without cuts in-between.

Select the Media Type

Selecting the media type that matches the media you are printing on will usually give the best print results.

Select this Media Type:	When you are printing on:
Plain Paper	Plain (uncoated) paper and labels.
Matte Coated Label	Matte coated labels.
Premium Matte Coated Label	Matte coated labels. This option uses more ink for better color.
Glossy Label	Glossy labels. This option optimizes print quality and dry time.
Premium Gloss Label	Glossy labels. This option uses more ink for better color.

Adjust Alignment for Printing

Always print a few test labels to check the alignment of the image. If the image is not centered, adjust the top of form and/or left edge offsets on the Media tab of the printer driver.

A positive value for **Top of Form** adjusts the image towards the top of the label.
A positive value for **Left Edge** adjusts the image towards the left of the label.

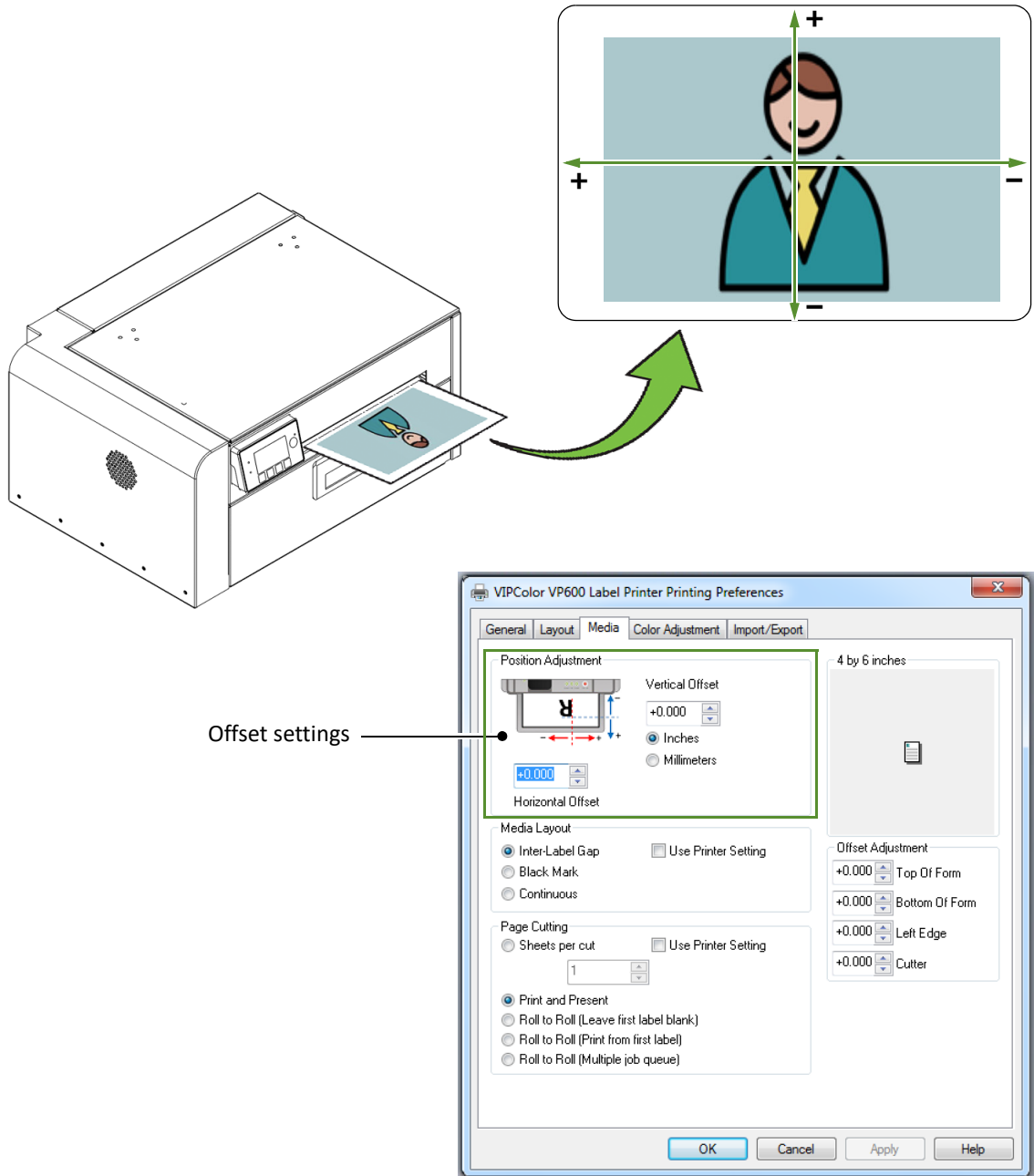

Printing Borderless (Full-Bleed) Labels

The usual approach to borderless printing is to prepare an image slightly larger than the label size, then center the larger image over the label so that it prints over the edges. The following procedure describes where to make the adjustments on the VP600 printer.

Note the following:

- This method requires fine-tuning of the printing position, which will be difficult if the label gap is very small e.g. 0.1" (3 mm).
- As the maximum label width is 8.5" (215.9 mm), it is also difficult to print borderless labels of this size. This method works best when the label width plus bleed allowance does not exceed 8.5" (215.9 mm).
- Print at 6 IPS only.
- You may need to fine-tune the Top of Form/Bottom of Form/Left Edge offset on the control panel for each label size. For example, the offsets for a 6" x 4" label may be different from a 2" x 2.5" label. Hence, you need to record the offsets used for each label size.

Adjustments for Borderless Printing

1. On the **General** tab of the printer driver (Figure 6), click **Custom Sizes** to set the page size slightly smaller than the label (about 0.01" or 0.2 mm in both direction).

Select **Print Speed** of **6 IPS** and enable **Borderless**.

2. On the **Media** tab, adjust the **Left Edge** to center the image on the label.
3. Print a few labels to check the print position.

Fine-tune using the printer control panel:

⚙️ (Config) → **ADJUST OFFSET** → Top of Form/Bottom of Form/Left Edge

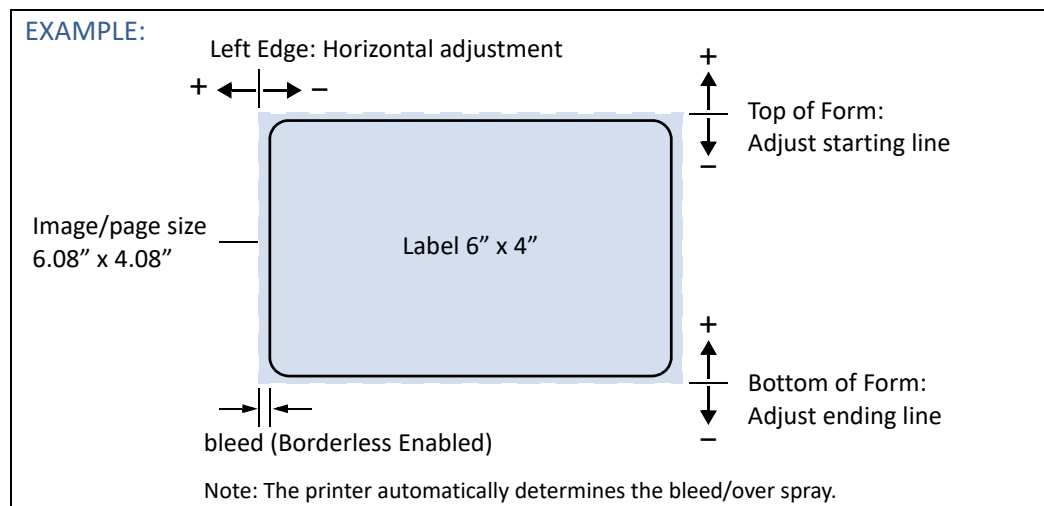

Saving Custom Media Size Settings

Any custom media size settings will be lost if the printer driver is updated. You can save a copy of these settings to a backup file. Then whenever you update the printer driver, you can import the settings from the backup file.

Export Custom Media Size Settings

1. On the **Import/Export** tab of the printer driver, select **Media Sizes**.
2. Click **Export**.
3. Enter a filename and click **Save**.

Import Custom Media Size Settings

1. On the **Import/Export** tab of the printer driver, select **Media Sizes**.
2. Click **Import**.
3. Select the file to import the settings from and click **Open**.

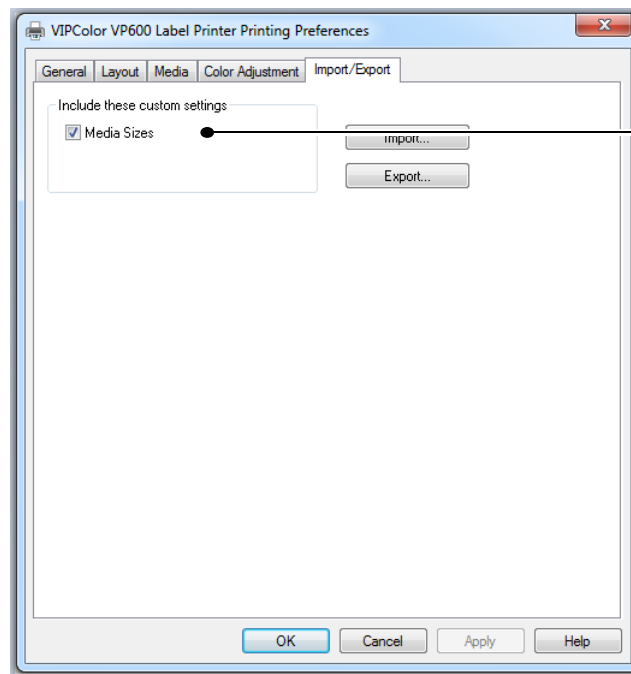

Select this option

Turning Off the Printer

Always use the Power button to turn off the printer.



Removing power to the printer in any other manner may damage the printer.

1. Press the Power button on the control panel, then press  (Select) to confirm.

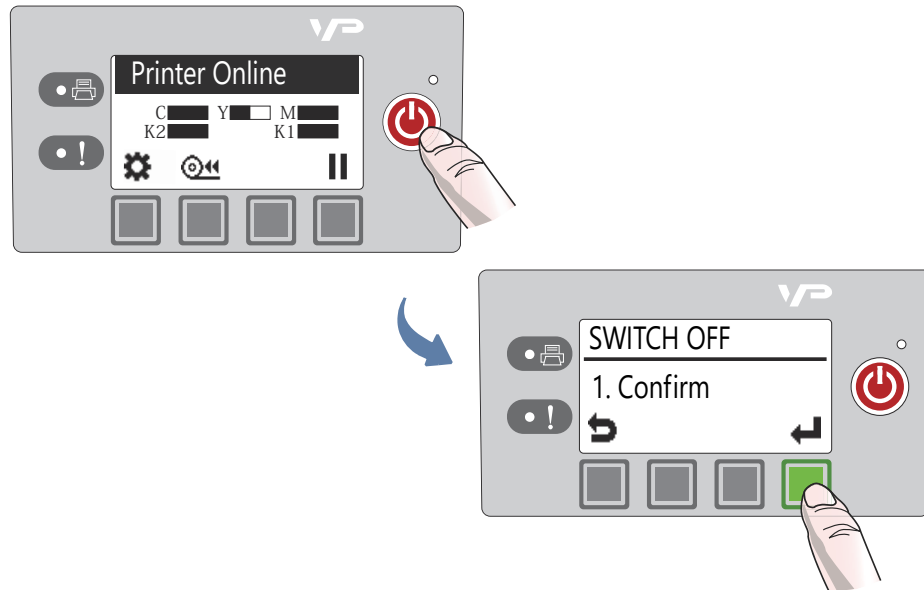

2. Wait for the LCD display on the control panel to turn off, then turn off the Power switch at the back of the printer.

During a normal shutdown, the printer will service the printhead and save data to the memory before turning off.

If the Printer Will Not Switch Off

If the printer does not respond when you press the Power button, press and hold the Power button for 5 seconds. The printer should switch off. However, it will not be able to perform the normal shutdown processes. Do not use this option unless it is absolutely necessary.

Managing Printer Security (Administrator)

The VP600 printer has three levels of security.

Security Level	Description
Level 0 (operator)	The printer powers up in level 0 by default, which allows users to access all the functions needed to print, but not to change printer parameters via the control panel.
Level 1 (supervisor)	The user can access certain printer parameters. A password is required to access this level.
Level 2 (administrator)	All parameters are enabled. A password is required to access this level.

The administrator can change the passwords through the Embedded Web Server (EWS). It is recommended that the administrator change the passwords once the printer has been set up. The default password is **123** for the EWS and the printer control panel.

Change Passwords

1. Log in to the EWS.
 - a On the Windows **Start** menu, select **All Programs > VIPColor > VIPColor VP600 Label Printer > Toolbox**.
 - b Click **VIPColor VP600 Label Printer** to launch the default web browser and open the EWS for your printer.
 - c Click **Login** to log in with your admin password.
2. Select **Security Setup**, then select **Printer Password**.

The screenshot shows the Embedded Web Server (EWS) interface for the VIPColor printer. The page is titled "Change EWS Security Password" and "Change Front Panel Security Password". The interface includes a navigation menu with options like LOGIN, PRINTER STATUS, SECURITY SETUP, NETWORK SETUP, DIAGNOSTICS, and ADVANCED SETTINGS. The "SECURITY SETUP" menu is selected, and the "PRINTER SECURITY" sub-menu is active. The main content area contains two sections: "Change EWS Security Password" and "Change Front Panel Security Password". The "Change EWS Security Password" section has fields for "User:", "New password:", and "Confirm password:", along with a "Submit" button. The "Change Front Panel Security Password" section has a "Security level:" dropdown menu set to "Level 2 - Admin", and fields for "New password:" and "Confirm password:", along with a "Submit" button.

3. Set the password and click **Submit**.
 - The EWS password can have 3 to 12 alphanumeric characters. Special characters are not allowed.
 - The control panel password must contain 3 digits.

Change Security Level for Printer Settings

The administrator can change the security level for the following protected printer settings, which are enabled at Level 1 by default.

1. Log in to the EWS.
2. Select **Security Setup** followed by **Printer Security**.

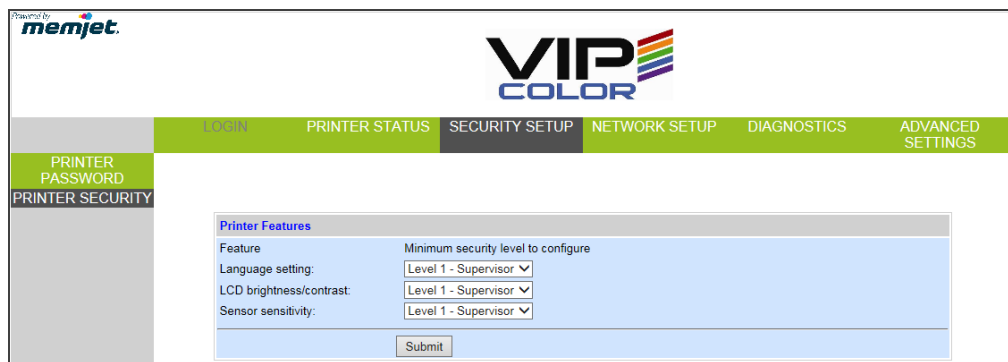

The screenshot shows the Memjet VIP COLOR printer's web interface. At the top, there is a navigation bar with the following tabs: LOGIN, PRINTER STATUS, SECURITY SETUP (highlighted), NETWORK SETUP, DIAGNOSTICS, and ADVANCED SETTINGS. Below the navigation bar, there is a sidebar menu with the following items: PRINTER PASSWORD and PRINTER SECURITY (highlighted). The main content area displays the 'Printer Features' configuration page. It includes a table with the following settings:

Feature	Minimum security level to configure
Language setting:	Level 1 - Supervisor
LCD brightness/contrast:	Level 1 - Supervisor
Sensor sensitivity:	Level 1 - Supervisor

At the bottom of the configuration area, there is a 'Submit' button.

3. From the dropdown list, select the minimum security level allowed to access each setting.

For example, if you set **Language** to **Level 0 - Operator**, then all security levels will have access to this setting.
4. Click **Submit**.

Embedded Web Server (EWS)

The Embedded Web Server (EWS) provides remote access to the printer. You can monitor the printer status and check usage metrics. The administrator can also log in to view additional information and change various settings.

1. On the Windows **Start** menu, select **All Programs > VIPColor > VIPColor VP600 Label Printer > Toolbox**.

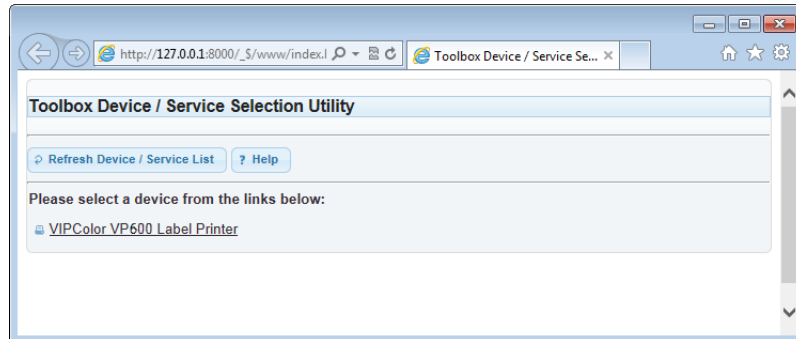

2. Click **VIPColor VP600 Label Printer** to launch the default web browser¹ and open the EWS for your printer.

The EWS displays printer information and usage metrics on the **Printer Status** page. Click **Login** to log in for full access to all the EWS pages.



1. Recommended: Internet Explorer 8/Firefox 15 or later, at 1280 x 700 or higher resolution.

The EWS contains the following pages:

- [Printer Status](#)
- [Security Setup](#)
- Network Setup
- [Diagnostics](#)
- [Advanced Settings](#)

Table 4 EWS: Printer Status

EWS Page	Description
Information	Shows printer and printhead information, and print counters. Control Panel – Click Launch to launch the remote control panel (Figure 7). This will display the same menu options that are provided on the printer control panel.
Ink Level	Shows ink levels and usage metrics. Ink usage metrics can be exported. Right-click the EXPORT link and select Save Target As to save the data in a file.
Local Settings	Shows the current printer settings.

Figure 7 Remote Control Panel

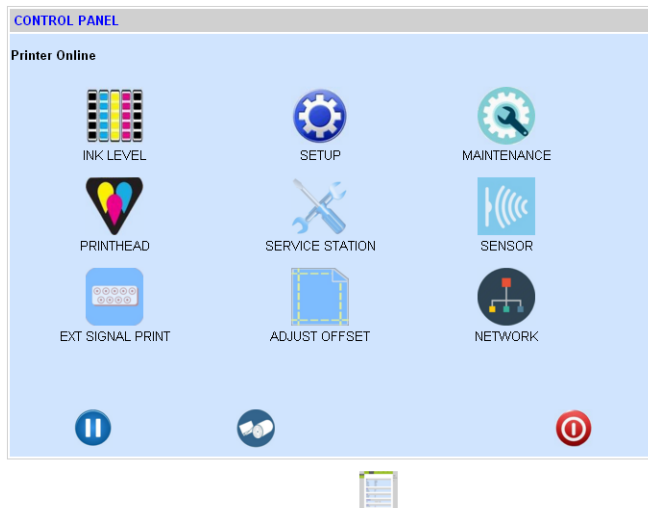

Table 5 EWS: Security Setup

EWS Page	Description
Printer Password	<p>Set the passwords for accessing the following:</p> <ul style="list-style-type: none"> • Embedded Web Server (EWS). • Level 1 (Supervisor) security on control panel. • Level 2 (Administrator) security on control panel. <p>The EWS password can have 3 to 12 alphanumeric characters. Special characters are not allowed.</p> <p>The control panel password must contain 3 digits.</p>
Printer Security	<p>Set the minimum security level allowed to access the following protected settings:</p> <ul style="list-style-type: none"> • Language • LCD brightness/contrast • Sensor sensitivity

For more information, see [Managing Printer Security \(Administrator\)](#) on page 25.

Table 6 EWS: Diagnostics

EWS Page	Description
Labels	Select the media type - Continuous, Gap or Black Mark for printing all the internal pages generated by the printer (i.e. Configuration Page, Network Settings Page and diagnostic test plots).
Sensor Threshold Values	<p>Run a length of labels (about 1m or 40") to record the readings of the gap/mark sensor without actually printing. The readings are analyzed to determine if there is sufficient contrast for the printer to reliably detect the inter-label gap or black mark.</p> <p>If necessary, you can then adjust the threshold value of the sensor to improve detection, especially when printing on non-rectangular label stock.</p> <p>See Adjusting Gap/Mark Sensor Thresholds.</p>
Override Auto Sensor Threshold	Set a threshold value for the gap or black mark sensor, based on the above analysis. Click Submit to send the new value to the printer.
Test Pages	<p>Print test page.</p> <ol style="list-style-type: none"> 1. Ensure the media loaded is of the required size and the media type is selected under Labels. 2. Click the icon to print the barcodes or diagnostic page.

Adjusting Gap/Mark Sensor Thresholds

1. Load the media to be tested.
2. On the EWS **Diagnostics** page, under **Sensor Threshold Values**:
 - a Select the test media type.
 - b Specify the length of the label (min. 1") and click **Submit** to apply the value.
 - c Click **TEST** to run the test.
 - d Click **GRAPH** to plot the readings.

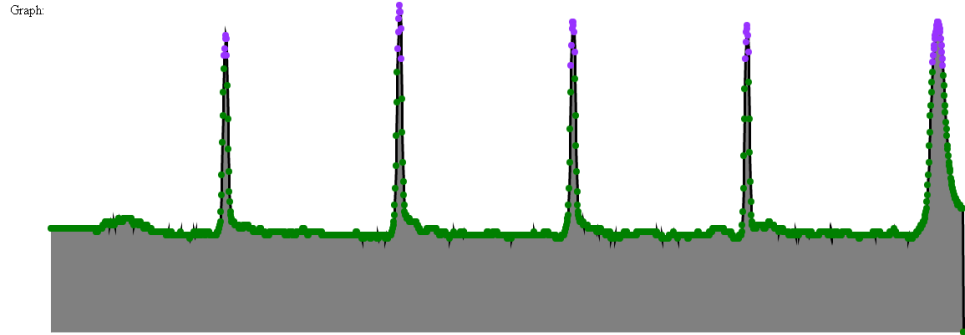

3. Review the graph and adjust the sensor threshold if needed, under **Override Auto Sensor Threshold**.

Interpreting the graph:

- **Normal** - Sharp spikes at regular intervals indicate that the sensor can clearly detect the gap (or mark) on the media. The above is an example of a normal graph.
- **Noisy** - Imperfect spikes at regular intervals. The printer may erroneously detect the Top-of-Form. For more reliable detection, reduce the sensitivity of the sensor to achieve a graph that is close to Normal.
- **Bad** - Readings are not distinctive. In this case, increase the sensitivity of the sensor. If the readings remain the same at maximum sensitivity, this means that there is insufficient contrast between the gap (or mark) and the liner. That is, this media is incompatible with the printer.

Advanced Settings

- [Advanced Settings 1](#)
- [Advanced Settings 2](#)
- [Import/Export Setting](#)

Table 7 EWS: Advanced Settings 1

EWS Page	Description
Remote commands	Select a command and click Submit to send it to the printer.
Mid Job Servicing Interval	<i>For roll-to-roll print mode only</i> Select a servicing interval and click Submit . The printer performs a servicing routine at the specified interval before it resumes printing.
Keep Unused Printhead Nozzles Wet Setting	Disable or select the firing frequency of unused printhead nozzles to keep them hydrated. By default, Automatic mode is selected, which assigns a fixed frequency suitable for each print mode.
Other Settings	
Retract media when printer is idle	When the media remains in the printer for some time, it may become deformed and affects the print quality. To avoid this, select this option.
Enable virtual printing	Simulate printing to estimate ink usage. <ol style="list-style-type: none">1. Select Enable virtual printing.2. Print in the usual way. The printer will not actually print, but will estimate ink usage for the print job.3. On the Printer Status page, select Ink Status to view the estimates. The control panel will display Simulation when the printer is in this mode.
Disable cut at the start of a print job	Do not cut the media at the start of a print job. Select this option to reduce paper dust/debris if the printer is used in a clean room.
Use fixed USB ID	When selected, the host PC uses a fixed USB ID and does not install a printer driver every time a printer is connected, reducing the printer setup time. Select this option if you need to hot-swap printers on the PC.
Enable Enhanced Fast-Time-To-First Label (ETTFL)	When selected, skip some printhead cleaning routines before the start of a print job, reducing the interval before the first label prints (Print and Hold mode).
Enable Extended Printhead Clean Cycle at the End-of-Job	When selected, extends the printhead cleaning cycle at the end of the print job. Use this option only for severe cases of streaking; it will consume more ink.

Table 7 EWS: Advanced Settings 1 (continued)

EWS Page	Description
Enable ink spit every 10 min in standby mode	Select this option to protect the printhead in a dry environment, characterized by low humidity (~20% RH) and low temperature (~15°C or 59°F).
Enable MM servicing message from control panel	When selected, servicing and error messages for the service station are displayed on the printer control panel.
Enable smart nozzle health extender algorithm	<p>When selected, repetitive images are printed using groups of adjacent nozzles in the printhead instead of using the same nozzles every time. This helps extend the printhead life. However, it causes a gradual shift of the image up to 1 mm to the left (viewing from the printer output).</p> <p>Do not select this feature if image shifting between labels is not desirable.</p> <p>This feature is ignored for Borderless printing.</p>
Cut the first label (for Length > 8") at media load	<p>When selected, the printer automatically cuts the first label (if > 8" long) when loading a new label roll.</p> <p>This eliminates media skew when the media is retracting.</p>
Enable support for translucent synthetic media in continuous print mode	Select this option to prevent the printer from incorrectly reporting a No Media error when semi-opaque continuous media is used.
Enable print over label gap and black mark	Select this option to continue printing an image across labels (over the gap or black mark on continuous media). For example, when printing wine labels, where the front and back labels are printed as a single page.
Enable Memjet TPS algorithm for printhead	<p>When selected, the printer will reduce the thermal energy for the printhead during power up. This helps prolong the printhead life.</p> <p>This may result in more discrete transition between color tones (or gradient).</p> <p>Do not select this option if your label design has solid color blocks or tone gradient.</p>
Do not unload media on power off	<p>When selected, the printer will not unload the media when it powers down.</p> <p>Note: Leaving the media in the printer for a long period of time may cause the media to curl and jam during printing.</p>
Improve gap detection for thick liners	<p>The typical label liner is about 0.06 mm or 0.0015". When using media with thick liners, it may be necessary to adjust the sensitivity of the gap sensor to enable the printer to reliably detect the gap between labels. (See Adjusting Sensor Sensitivity on page 70.)</p> <p>If adjusting the sensitivity of the gap sensor does not work, select this option.</p> <p>If the problem persists, we advise that you switch to another media that is compatible with the printer.</p>

Table 7 EWS: Advanced Settings 1 (continued)

EWS Page	Description
Display last job page count when printer is idle	When selected, the number of labels printed will be displayed on the front panel until the next print job starts.
Disable COM port	When selected, the printer will ignore or not transmit signals through the COM port, which is used mainly for debugging.
Disable Input sensor detection while printing	When selected, the printer will ignore the input sensor. This feature is useful to prevent the printer from incorrectly recognizing the end of the media roll, which may happen when the media has a thick liner that makes gap or black mark detection difficult.
Enable blank page after every job in multiple job queue	When selected, the printer will not print on the first label when starting each job in the multiple job queue.
Enable advanced end of roll handling	Select this option to allow the following when printing roll to roll: When the printer encounters the end of the roll with a printed label in the cutter module, the printer will pause to allow the user to release the media from the core. Then the printer will cut and eject the remaining media from the printer when the user presses the Eject button on the control panel.
Advanced media check	When selected, the printer will check the media roll and report an error if the media is not correct for the print job.
Disable media cut while cancelling a job (Multiple Job Queue)	When selected, the printer does not cut the media if a job is cancelled in a multiple job queue.
Disable label length check when loading a new label stock	When selected, the printer does not check the label length when a new media roll is loaded.

Table 8 EWS: Advanced Settings > Advanced Settings 2

EWS Page	Description
Printer Pause Settings	<ul style="list-style-type: none"> • Pause The printer will print labels at the selected time interval. • Print & Present Move the printhead to the capped position at the selected time interval after the last print. • Multiple Job Queue Cut the media and move the printhead to the capped position if the next print job in the queue is not received after waiting for the selected time interval. • Out of Ink Cut the media and move the printhead to the capped position after the selected time interval if the printer runs out of ink. • End of Job Move the printhead to the capped position at the selected time interval after printing is completed.
Media Gap Setting	<ul style="list-style-type: none"> • Specify the inter label gap when using continuous media. Click Submit to apply the new value. • Specify the maximum gap, if using non-standard gap labels. Click Submit to apply the new value. (3 mm or 0.125" is standard for gap labels.)
Printhead Service Setting	<ul style="list-style-type: none"> • Specify the servicing level when the ink door is closed. • Specify the pre-job printhead service level.
Fine-tune linefeed calibration	<p>When printing large images, the printed image may be slightly shorter due to the linefeed. Fine-tune by entering a correction (stretch) factor calculated as follows:</p> $\text{Correction factor} = (\text{Printed Length} \div \text{Image Length}) * 1,000,000$
Wiper Maintenance Schedule	Specify the time interval for the wiper to clean itself. Use this option in a dry environment (10% RH or less) to prevent the wiper roller becoming too dry for it to properly wipe and clean the printhead.
Cut After Print Setting	Set the delay before the printer cuts the label after printing it.
Printer Shutdown Schedule	Shut down the printer daily at a specific time. Click Submit to save the settings.

Table 9 EWS: Advanced Settings > Import/Export Settings

EWS Page	Description
Import Setting	Import the Advanced Settings from another printer.
Export Setting	Export the Advanced Settings to another printer.

Other Support Tools

On the Windows **Start** menu, select **All Programs > VIPColor > VIPColor VP600 Label Printer > Support Tools**.

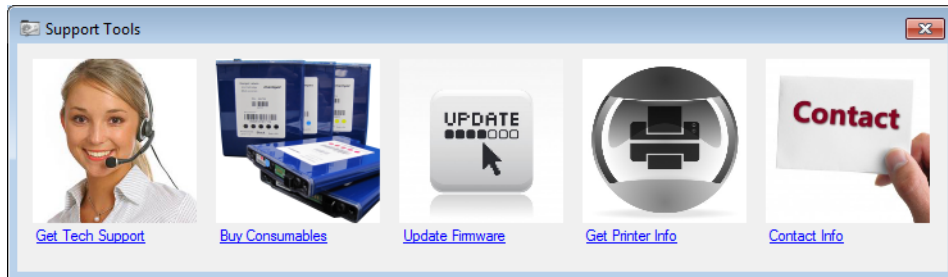

The Support Tools consist of the following:

- **Get Tech Support:** Opens the Technical Support web page.
- **Buy Consumables:** Opens the consumables web page for you to purchase ink supplies online.
- **Update Firmware:** Helps you to update the printer firmware.
- **Get Printer Info:** Displays a log of printer activity and errors. This may be required when you contact Technical Support.
- **Contact Info:** Allows you to save your contact information, which will be included in the Printer Info log.

Chapter 2

Printer Maintenance

Guidelines for Preventive Maintenance	38
Replacing an Ink Cartridge	39
Cleaning the Printhead	40
Replacing the Printhead	41
Opening/Closing the Clamshell	44
Cleaning Debris from the Cutting Zone	45
Cleaning the Sensors	46
Replacing the Output Module/Cutter Assembly	47
Replacing the Service Station	51
Replacing the Transfer Wiper Assembly	54
Replacing the Aerosol Fan Filter	56
Replacing the Waste Ink Absorber	57

Guidelines for Preventive Maintenance

Recommended maintenance depends on the print mode that is most frequently used. If you mostly print Roll to Roll ($\geq 80\%$), refer to [Table 10](#). Otherwise, see [Table 11](#). **Inspect** means to check the condition and replace if necessary.

Note that these are general guidelines for preventive maintenance. As operating conditions for your printer may differ, adjust your maintenance schedule accordingly.

Table 10 Maintenance Schedule: For $\geq 80\%$ Roll to Roll Operation

Part		Every 1M inches (25,400 m)	Every 2.5M inches (63,500 m)	Every 5M inches (122,500 m)
Sensors		Clean	–	–
Cutter Assembly	MM007-64506	–	Inspect	Replace
Output Module	VMAG1-60008A	–	Inspect	Replace
Service Station	MM007-65502	Inspect	Replace	–
Transfer Wiper Assembly ¹	MM007-65505	Inspect	Replace	–
Aerosol Fan Guard	VMAG1-70150A	–	Replace	–
Waste Ink Absorber	MM007-10005	–	–	Inspect

Table 11 Maintenance Schedule: For $\geq 80\%$ Roll to Cut/Print and Present Operation

Part		Every 1M inches (25,400 m)	Every 2.5M inches (63,500 m)	Every 5M inches (122,500 m)
Sensors		Clean	–	–
Cutter Assembly	MM007-64506	Inspect	–	–
Output Module	VMAG1-60008A	Inspect	–	–
Service Station	MM007-65502	Replace	–	–
Transfer Wiper Assembly ¹	MM007-65505	Replace	–	–
Aerosol Fan Guard	VMAG1-70150A	–	Replace	–
Waste Ink Absorber	MM007-10005	–	–	Inspect

1. The transfer wiper assembly is part of the service station and may not be available as a separate replacement for your printer. If it is not available, follow the maintenance schedule for the service station.

Replacing an Ink Cartridge



Do not open the front cover if the control panel shows Servicing Printhead. Wait for the servicing to be completed first.

1. Open the front cover of the printer.

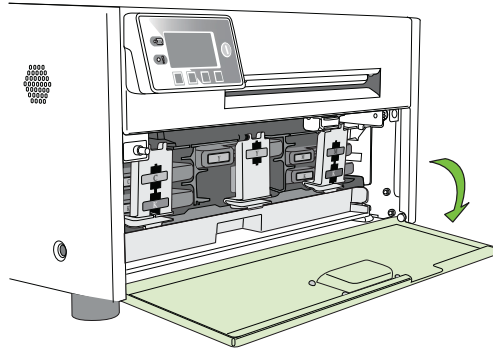

2. Open the latch and remove the empty ink cartridge.

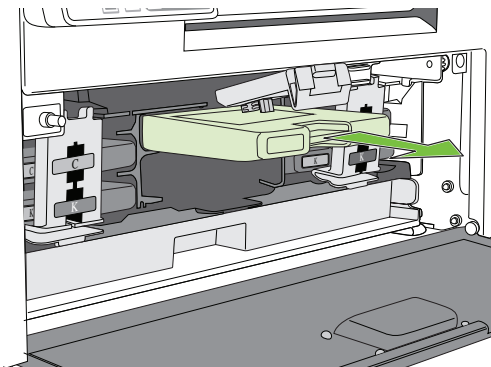
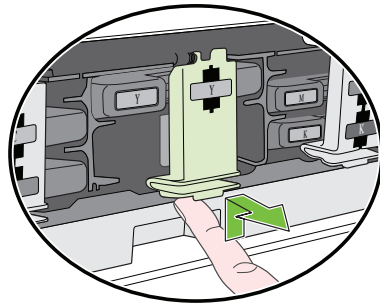

3. Insert the new cartridge and close the latch.

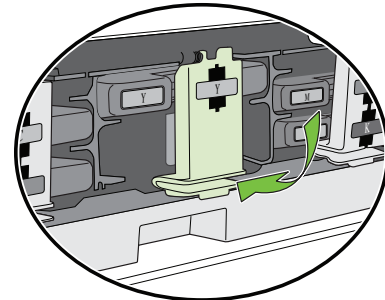
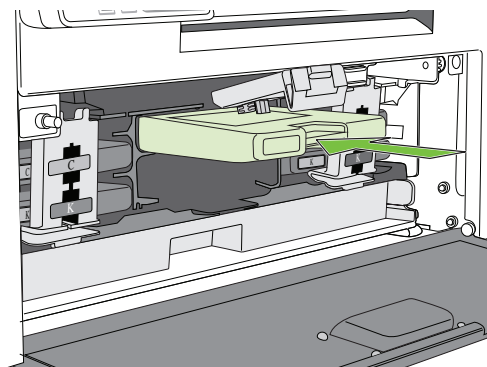

4. Close the front cover.

NOTE: Dispose of the empty ink cartridge according to local regulations.

Cleaning the Printhead

The printer provides three automated cleaning cycles for the printhead: Normal, Extended, and Extreme. Always start with the Normal cleaning cycle and proceed to the next level only if print quality does not improve.

1. On the control panel, select  (Config) → PRINTHEAD → CLEAN → Normal

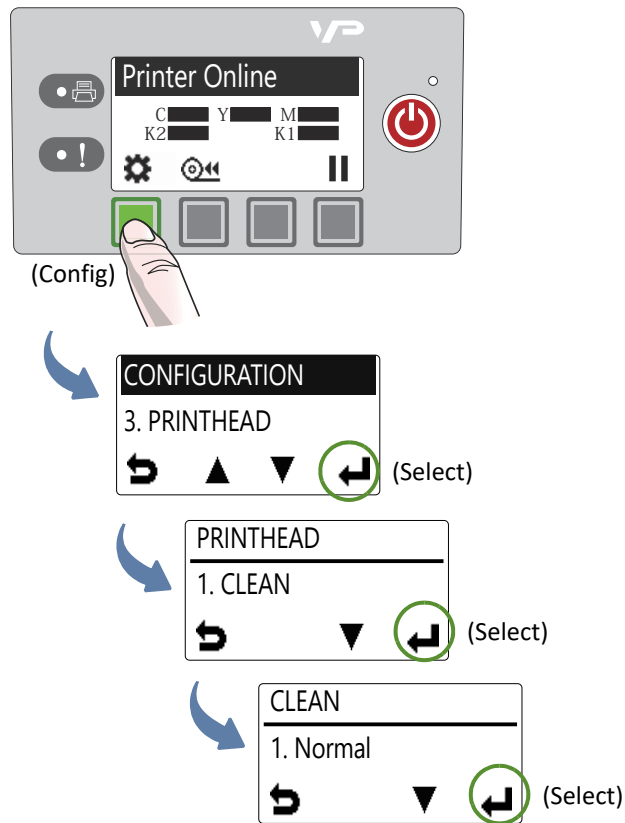

2. After the cleaning is completed, try printing again.

Replacing the Printhead

Make sure all the ink cartridges are installed before replacing the printhead.

1. Open the printer top cover.
2. On the control panel, select  (Config) → PRINTHEAD → Replace.

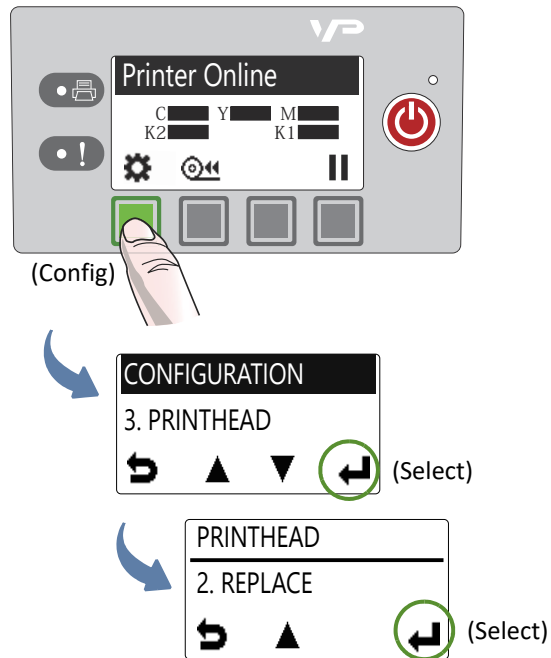

Wait for the printhead latch to be released. It will pop open. **DO NOT** force it open as it may break.

3. When the printhead latch is released, open the latch fully.

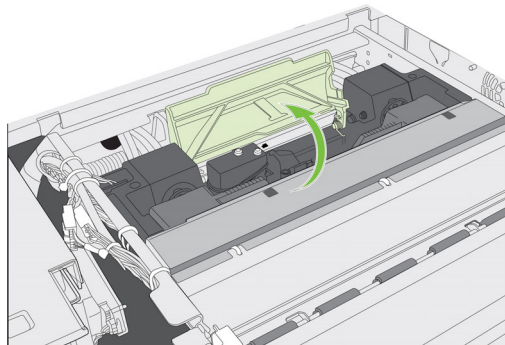

4. Hold the printhead by the handle and push it toward the printhead latch. Once the printhead is released, lift it out of the printer.

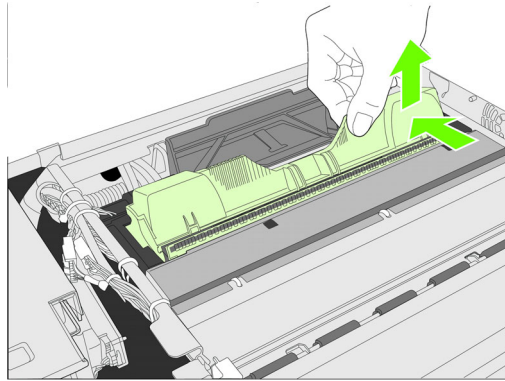

NOTE: Dispose of the old printhead according to local regulations.

5. Remove the new printhead from its packaging.

 Do not touch the ink couplings, electrical contacts, or nozzles.

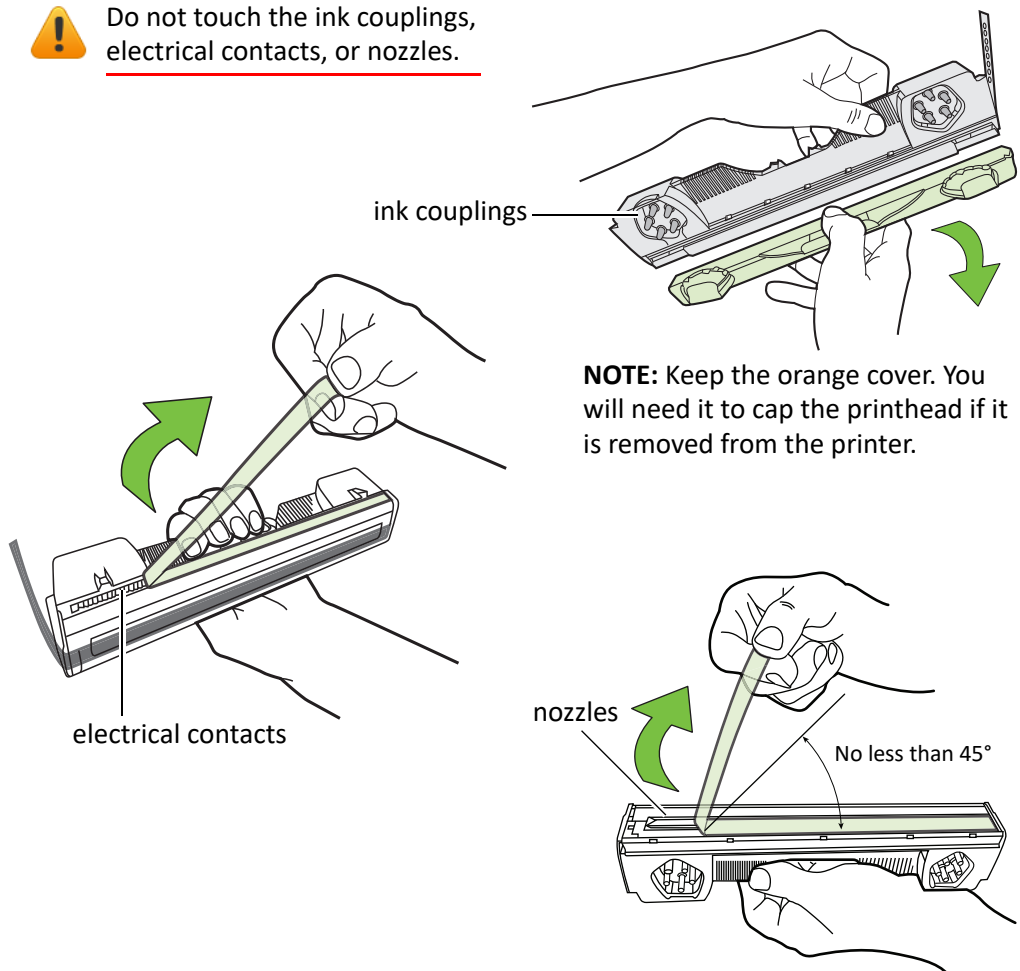

6. Slide the printhead into the slot. Push it toward the front of the printer. It should snap into place.

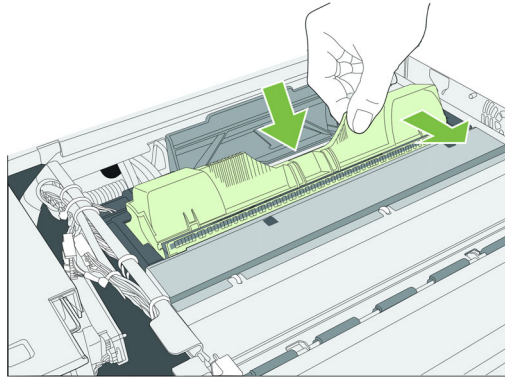

7. Close the printhead latch.

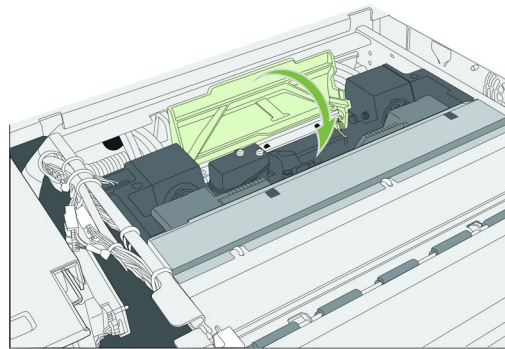

Check that ink is flowing through the tubes on both sides of the printhead.

8. Close the top cover.

Opening/Closing the Clamshell

In the following procedures you may need to open the clamshell in order to access the areas inside the printer.

Opening the Clamshell



Do not open the top cover if the control panel shows Servicing Printhead. Wait for the servicing to be completed first.

1. Open the top cover.
2. Squeeze the latches on either side of the clamshell and open the clamshell to its highest position.

squeeze clamshell latches

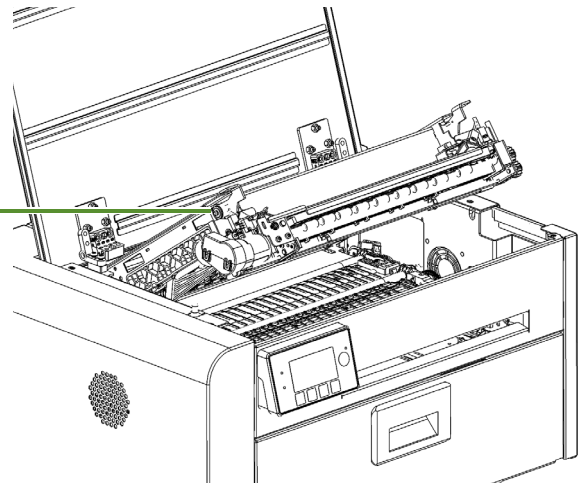
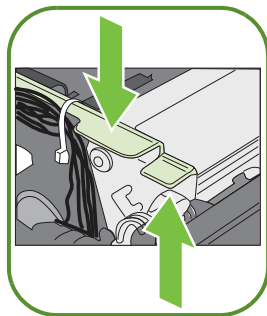

Closing the Clamshell

Squeeze and hold the clamshell latches while you gently lower the clamshell back into place.



Do not allow the clamshell to drop when closing it.

Cleaning Debris from the Cutting Zone

Clear all debris from the cutting zone to avoid contaminating the print zone, especially fine dust particles.

1. Open the top cover.
2. Vacuum any debris from the cutting zone.
3. **Open the clamshell** and also check below the cutting zone, at the bottom of the printer and in front of the ink cartridges.

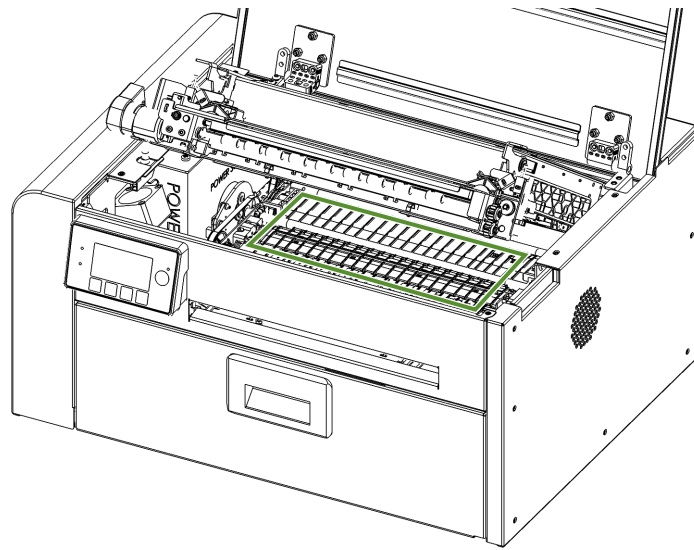

Cleaning the Sensors

Always keep the media path clean as accumulated dust can affect printing.

1. [Open the clamshell](#) to its highest position.
2. Vacuum any dust or debris from the sensors.
Use the rollers to help you locate the sensors as shown in [Figure 8](#).
3. Clean ink from the exit sensor if it looks dull:
 - a Fold a lint-free cloth to form a tip and lightly moisten with de-ionized water. Insert it in the opening to clean the exit sensor.
 - b Repeat with a clean part of the cloth if necessary.
 - c Let the sensor dry before continuing.
4. [Close the clamshell](#) and top cover.



Do not vacuum the printhead.

Figure 8 Location of sensors

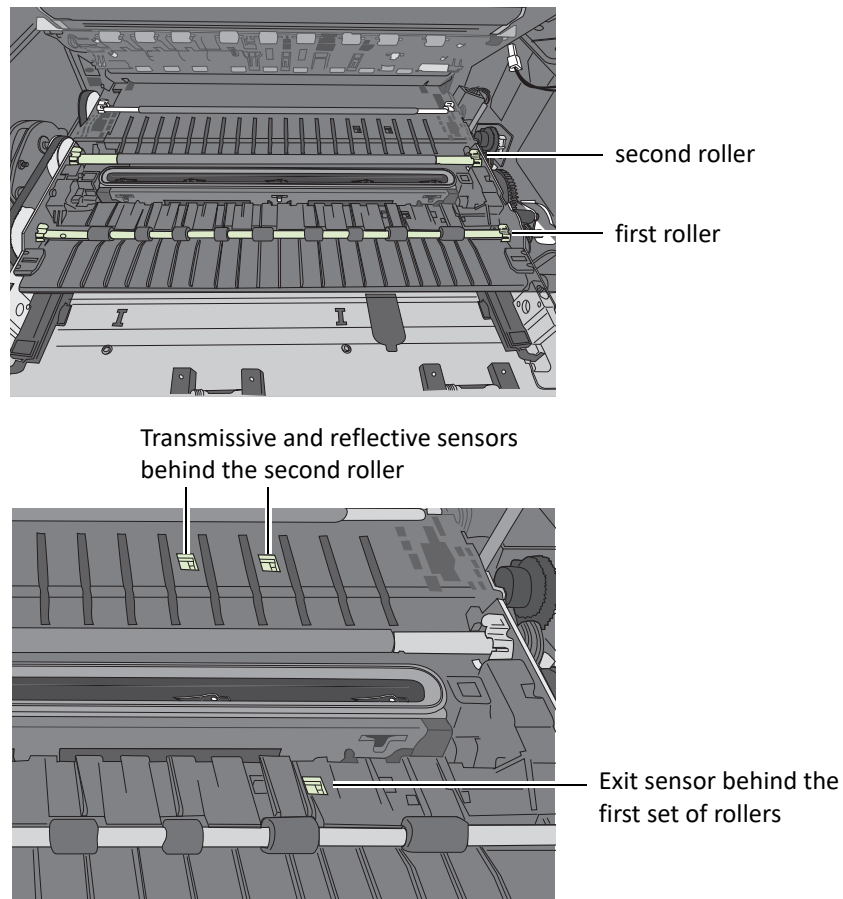

Replacing the Output Module/Cutter Assembly

- Tools**
- Nitrile powder-free gloves
 - Small flat-head screwdriver
 - T10 Torx driver
 - Scissors or cutter (for cable ties)
 - Cable ties

Keep the cutting zone free from debris. Check cut labels to ensure that the cuts have clean edges and replace the cutter assembly when necessary.

NOTE: Before you begin, remove the printhead and cap it with the orange protective cover.

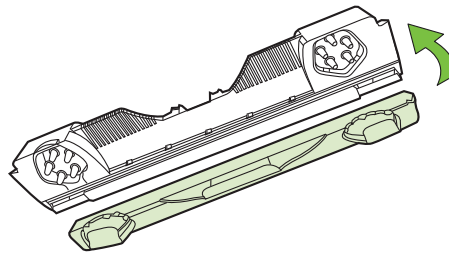

Removal

1. Press the Power button on the control panel to turn off the printer. Also turn off the Power switch at the back of the printer.
2. [Open the clamshell](#) to its highest position.
3. Locate the wire harness connector (labeled P107) for the output module ([Figure 9](#)). Use a small flat-head screwdriver to release the connector and separate it.

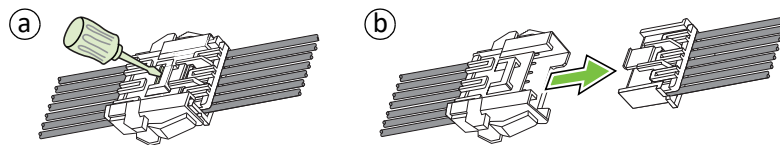

4. Carefully cut the cable ties securing the cables to the left side of the clamshell.



Be careful not to cut any of the cables.

Figure 9 Connectors and cables on left side of clamshell

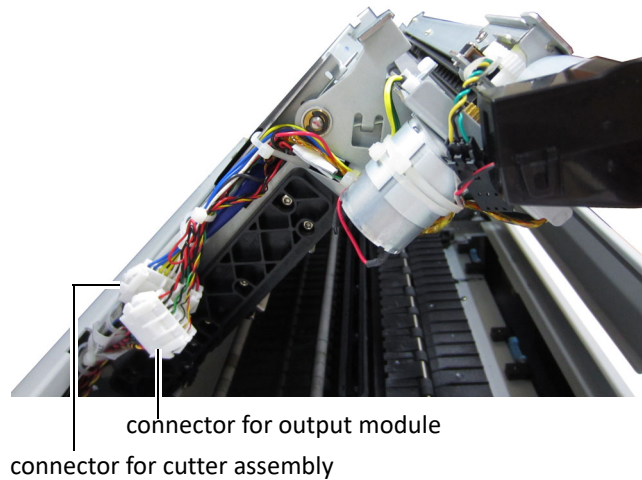

5. Use a T10 Torx driver to remove the four screws securing the output module. Remove the outer screws (a) first.

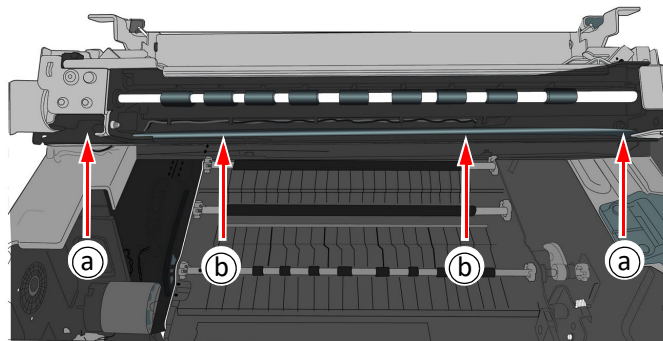

6. Carefully remove the output module from the clamshell. There is a black cable looped across the bottom of the output module. Gently pull the cable away from the bottom corners of the output module and ease the output module out.

The cutter assembly is now visible ([Figure 10](#)).

Replace Cutter Assembly

If replacing the cutter assembly, continue with the following steps.

1. Use a small flat-head screwdriver to release the wire harness connector for the cutter assembly (labeled CUTTER MODULE) and separate it (Figure 9).
2. Remove the two screws (a) securing the cutter assembly and remove the assembly (Figure 10).

Figure 10 Cutter assembly on clamshell

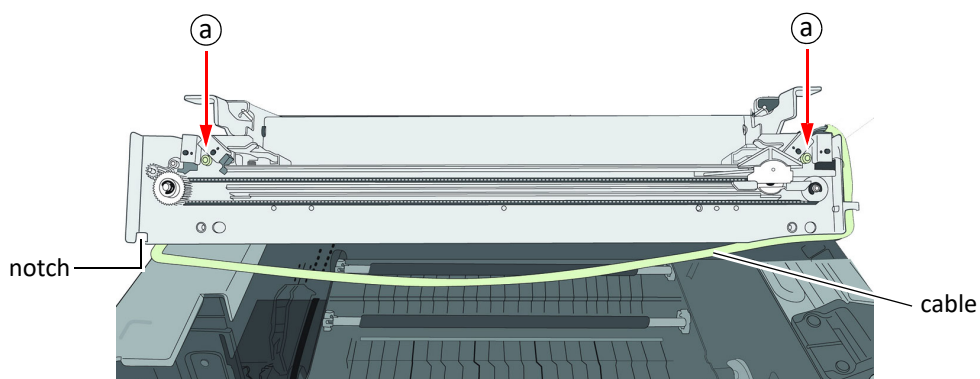

3. Line up the mounting holes and guides on the new cutter assembly and the front of the clamshell. Insert and tighten the screws to secure the assembly.
4. Make sure the cutter is at the side of the cutter assembly.

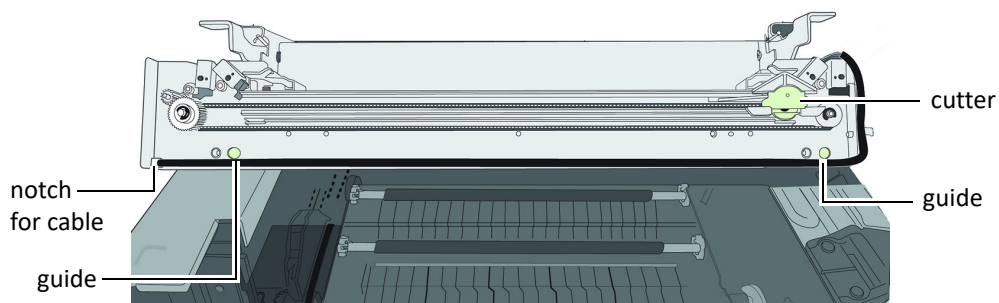

5. Reattach the wire harness connector (labeled CUTTER MODULE) for the cutter assembly at the side of the clamshell (Figure 9).



Be sure to reattach the correct connector for the cutter assembly.

6. Gently pull the black cable out of the notches at the bottom corners of the cutter assembly so that the output module can be installed.

Installation

1. Seat the output module on the cutter assembly, aligning the mounting holes for the screws.
2. Loop the black cable over the bottom of the output module, pushing it back into the notches at the corners of the cutter assembly.
3. Replace the four screws securing the output module. Replace the two screws in the center (b) before replacing the outer ones.

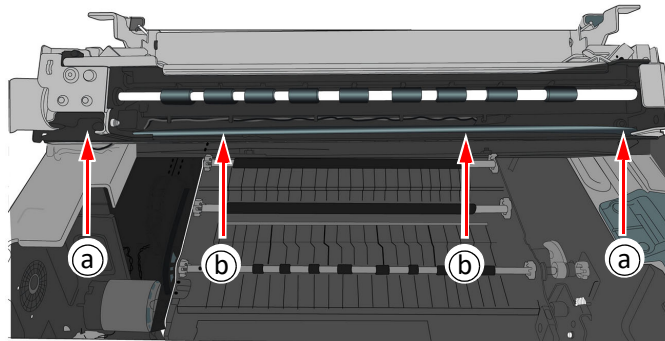

4. Reattach the wire harness connector (labeled P107) for the output module at the side of the clamshell (Figure 9).



Be sure to reattach the correct connector for the output module.

5. Tidy the cables at the side of the clamshell and secure with cable ties (Figure 9).
6. Carefully **close the clamshell** while checking that none of the cables will get caught or pinched.
7. Close the top cover.

Replacing the Service Station

NOTE: Before you begin, remove the printhead and cap it with the orange protective cover.

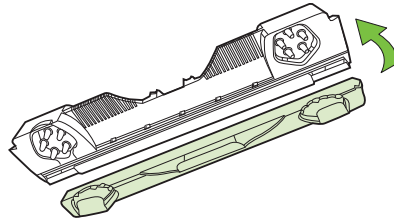

- Tools**
- Nitrile powder-free gloves
 - T20 Torx driver
 - Disposable towels

Removal

1. [Open the clamshell](#) to its highest position.
2. On the control panel, select  (Config) → SERVICE STATION → Eject.
Wait for the printer to eject the service station.
3. Press the Power button on the control panel to turn off the printer. Also turn off the Power switch at the back of the printer.
4. Remove the front panel:
 - a Use a T20 Torx driver to remove the four screws (labeled 1 to 4) securing the front panel.
 - b Release the front panel and disconnect the two cables behind the control panel.

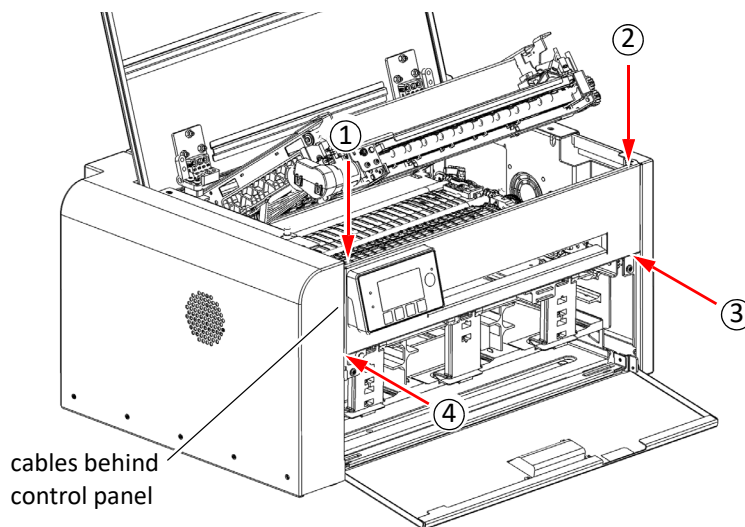

5. Pull the service station forward until you can disconnect the flex cable to the wiper motor. Loosen the clip on the connector (Figure 11) to release the flex cable.

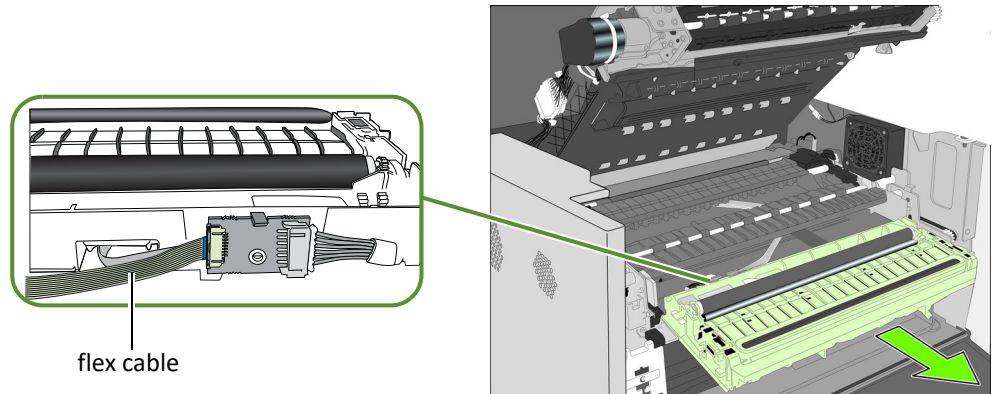

 Ensure that the flex cable does not come into contact with any metallic surface. If it is touching metal and the printer is accidentally turned on, it will short the controller circuit and damage the printer.

 Take care when handling the service station. Ink may spill when you tilt the service station.

NOTE: Dispose of the old service station according to local regulations.

Installation

6. Insert the flex cable into the connector on the new service station and push in the clip to secure it.

Figure 11 Flex cable to connector on service station

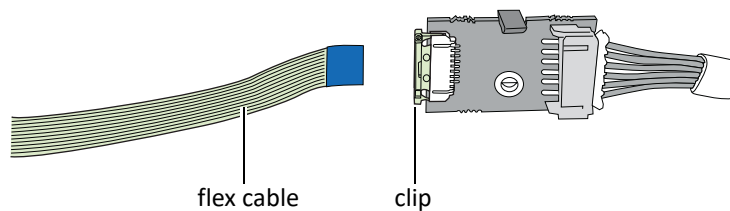

7. Carefully align the service station with the guide rails and slide it into the print engine. Push it in by applying even pressure near the edges, to ensure that the it goes in straight.

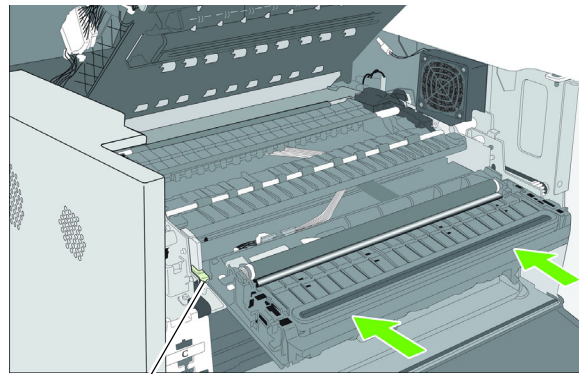

guide rail

Check the alignment: the cap on the service station must be parallel with the edge of the platen as shown below.

If the service station is skewed sideways, pull it out and reinsert.

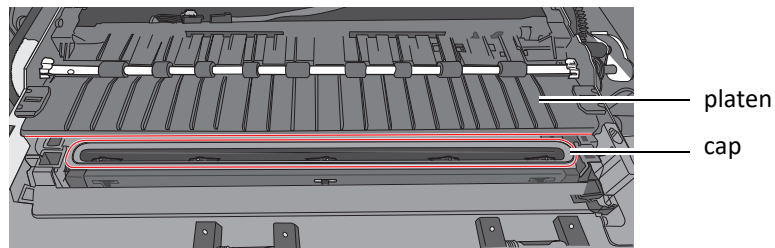

8. Continue pushing the service station while you manually rotate the positioning gear backwards to move the service station all the way into the print engine.

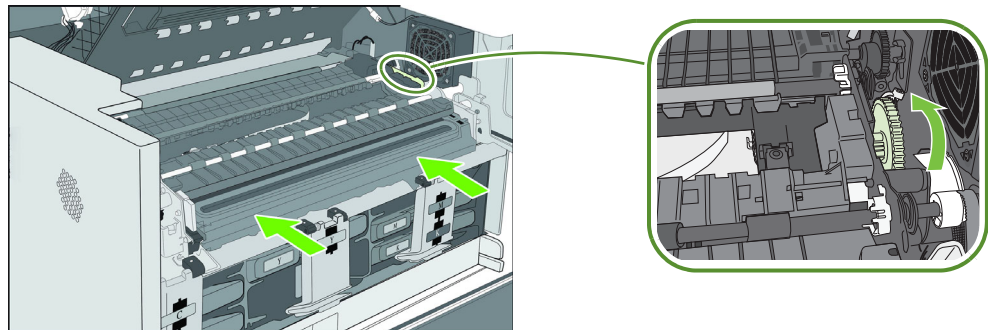

9. Reinstall the front panel: Reconnect the two cables to the front panel and replace the screws.
10. [Close the clamshell](#) and the covers.
11. Turn the printer on.

Replacing the Transfer Wiper Assembly

Removal

1. Follow the instructions to [remove the service station](#).
2. Disconnect the wiper motor cable from the PCB.
3. Release the PCB from the mounting clip.

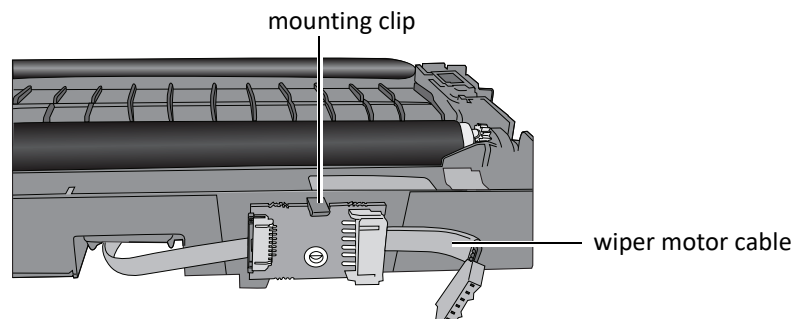

4. Route the cable through the housing as you remove the transfer wiper assembly.

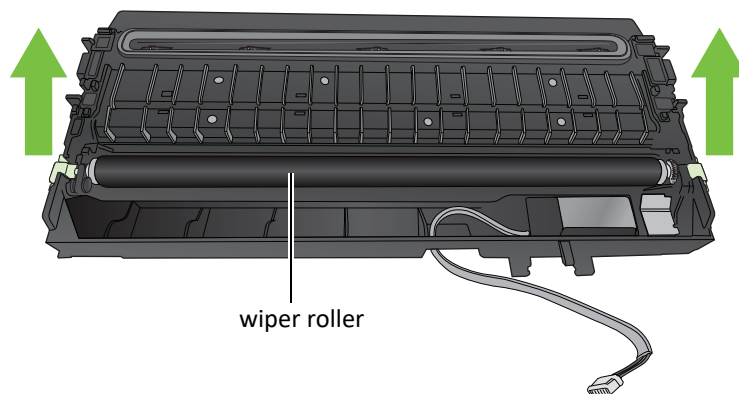

NOTE: Dispose of the old transfer wiper assembly according to local regulations.

Installation

5. Route the wiper motor cable through the housing as you insert the new transfer wiper assembly into the service station.

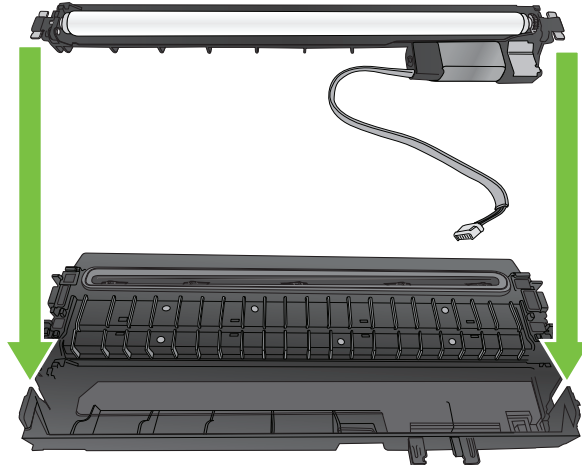

6. Push the cable between the clips. Align the PCB with the mounting clip and push gently into place.

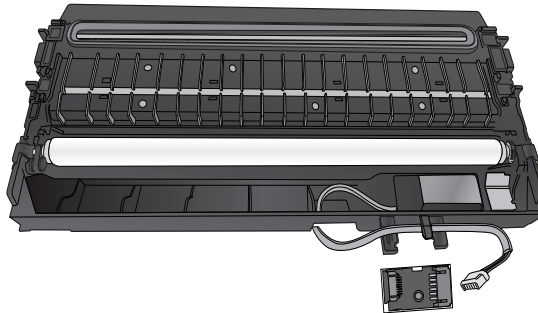

7. Connect the wiper motor cable to the PCB.

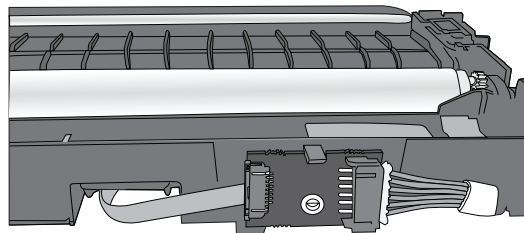

8. [Install the service station](#) in the printer.

Replacing the Aerosol Fan Filter

You can replace the aerosol fan guard or just replace the fan filter.

- Tools**
- Nitrile powder-free gloves
 - T20 screwdriver

Figure 12 Aerosol fan guard

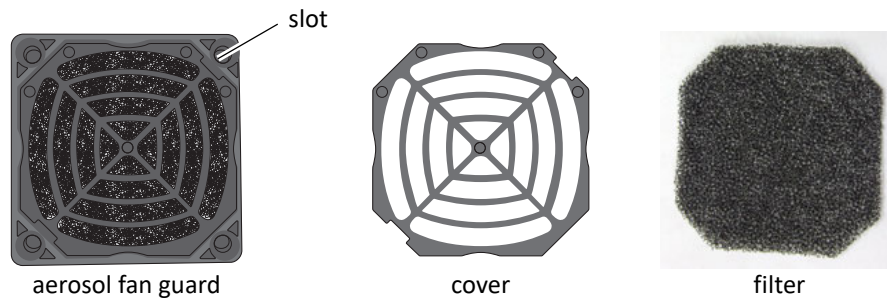

1. Remove the printer's side panel

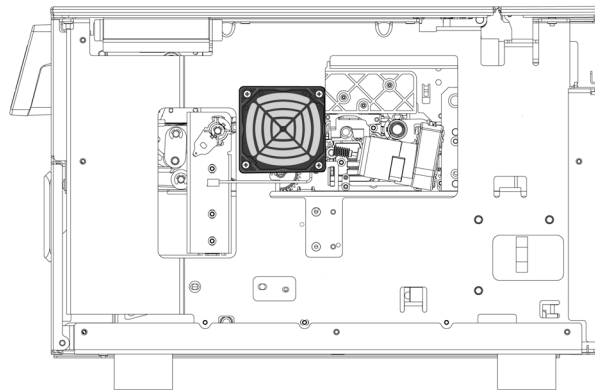

2. Disconnect the power cable.
3. Carefully remove the four screws at the corners of the fan guard. The fan guard can then be removed.
4. Align the new fan guard with the mounting holes and replace the screws.
5. Reconnect the power cable.
6. Replace the side panel.

Replacing the Waste Ink Absorber

Tools • Nitrile powder-free gloves

1. Open the front cover of the printer.

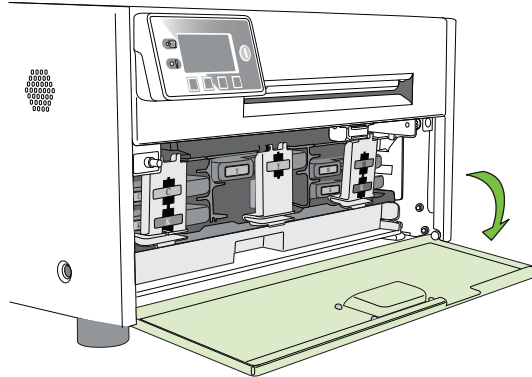

2. Squeeze the latches on both sides of the waste ink tray and pull it out.

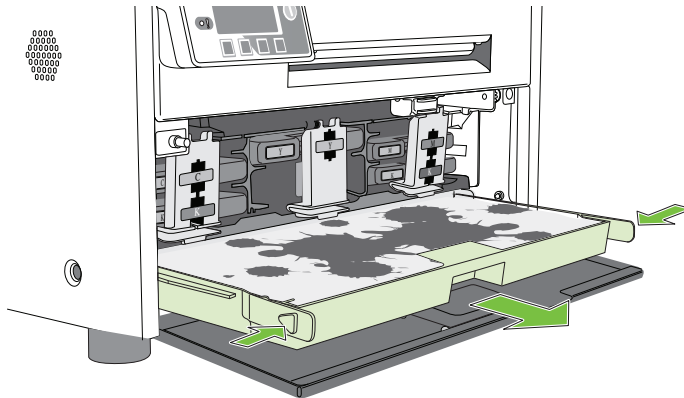

3. Remove the waste ink absorber and replace it with a new one.
4. Slide the waste ink tray into the printer. Push it in till it clicks into place.
5. Close the front cover.

NOTE: Take care when replacing the waste ink absorber to avoid staining hands and clothing. Dispose of the used waste ink absorber according to local regulations.

Chapter 3

Troubleshooting

If Error Messages Appear	60
Poor Print Quality or Incorrect Printout	64
Other Printing Problems	67
Clearing a Media Jam	68
Clearing Clogged Ink Nozzles	68
Adjusting Sensor Sensitivity	70

If Error Messages Appear

If error messages are displayed on the printer control panel, check the following table for the solution.

Error Message	Possible Cause	Solution
Clamshell Open	The clamshell is open.	Close the clamshell.
	The clamshell sensor is damaged	Contact Technical Support for part replacement.
End of media	End of media is detected.	Load a new roll or stack of labels.
Front Cover Open	The front cover is open.	Close the front cover.
	The front cover sensor is damaged.	Contact Technical Support for part replacement.
Jammed Cutter	Debris in the cutting zone.	<ol style="list-style-type: none"> 1. Turn off the printer and unplug the power cable. 2. Clean any debris from the cutting zone. See Cleaning Debris from the Cutting Zone on page 45 for details.
	The cutter has reached the end-of-life or the blade is blunt.	Contact Technical Support for part replacement.
Jammed Media	The labels are jammed or cannot feed into the printer.	Clear the jam and reload the media. See Clearing a Media Jam on page 68.
	Media used exceeds the maximum thickness of 0.01" (0.3 mm).	Clear the jam and replace the media. See Choosing Label Media on page 12.
	The transmissive (gap) or reflective (black mark) sensor is dirty or faulty.	Clean the sensor with a lint free cloth and re-try. If the error persists, contact Technical Support for part replacement.
Low Ink	An ink cartridge is low.	Replace the ink cartridge. Check the ink status icons for the color that is running out.
Mech Error [01]	The printer is not receiving the correct data.	<ol style="list-style-type: none"> 1. Check that the label & image size matches. Increase or decrease the image size slightly. 2. Cancel the job print (and clear the printer spooler, if needed) and re-try. 3. If the error persists, contact Technical Support.

Error Message	Possible Cause	Solution
Mech Error [code] where [code] > 01	Printer mechanical fault.	Note the error code and contact Technical Support. If Mech Error 2 or Mech Error 3a/3b appears during installation, see Troubleshoot Printer Setup on page 63. Do not attempt to restart the printer more than 3 times if the same Mech Error appears. Contact Technical Support.
Media Cover Open	The media cover is open.	Close media cover.
	The cover sensor is damaged	Contact Technical Support for part replacement.
Missing Ink Tank	The ink cartridge is not installed or not a genuine ink cartridge from the manufacturer (OEM).	Install a genuine ink cartridge. If the problem persists, contact Technical Support.
	The Ink cartridge is not properly installed.	<ol style="list-style-type: none"> 1. Remove and re-insert the ink cartridge. 2. Wait 10-15s for detection. If the ink tank remains undetected, repeat the process. 3. If the ink tank remains undetected after the third attempt. Restart the printer and repeat step (1) & (2). 4. If the problem persists, contact Technical Support.
	The ink cartridge is faulty.	Replace the ink cartridge.
	The electrical contact is obstructed or dirty.	Clean contact with a lint free cloth and re-insert.
	The ink cartridge latch is damaged or cannot be closed properly.	Contact Technical Support for part replacement.
Missing Printhead	The printhead is not installed or not a genuine printhead from the manufacturer (OEM).	Install a genuine printhead. If the problem persists, contact Technical Support.
	The printhead is faulty.	<ol style="list-style-type: none"> 1. Insert another printhead (or a known good printhead) and check if the printer is able to detect the printhead. If the problem persists, contact Technical Support.
	The electrical contact is obstructed or dirty	<ol style="list-style-type: none"> 1. Clean the contact with a lint-free cloth. 2. Re-insert the printhead. If the problem persists, contact Technical Support.

Error Message	Possible Cause	Solution
No Media	No media is detected.	Load a new roll of labels.
	The media is not properly inserted into the input guide.	Re-load the media.
Wrong Media	Problems with the media.	See Printer feeds media without printing on page 67.
Top Cover Open	The top cover is opened.	Close the top cover.
	The top cover sensor is damaged.	Contact Technical Support for part replacement.
Out of Ink	An ink cartridge is out of ink.	Replace the ink cartridge. Check the ink status icons for the color that is empty.

Table 12 Troubleshoot Printer Setup

Possible Cause	Solution
Service station is jammed.	Ensure that the cardboard is removed from inside the printer.
Service station was tilted during shipment.	<ol style="list-style-type: none">1. Turn off the printer: Press the Power button on the control panel, then press  (Select) to confirm. When the LCD display turns off, turn off the Power switch at the back of the printer.2. Open the clamshell to its highest position.3. Rotate the positioning gear forward to eject the service station.4. Push the service station back in, making sure it goes in straight. Check the alignment: the cap on the service station must be parallel with the edge of the platen.5. Continue pushing the service station while you manually rotate the positioning gear backwards to move the service station all the way into the print engine.6. Close the clamshell and turn on the printer.

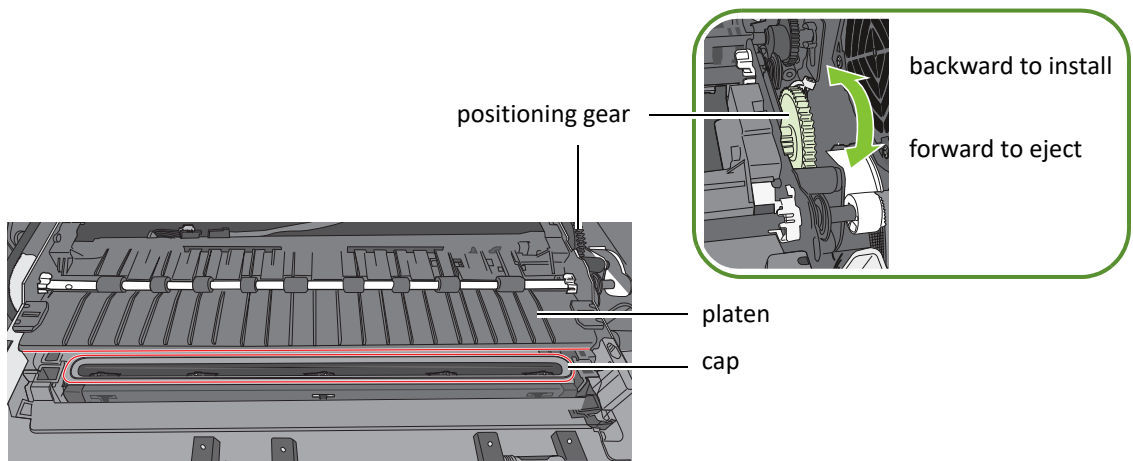

Poor Print Quality or Incorrect Printout

Problem	Possible Cause	Solution
Long stripes of missing print or vertical light streaks on several labels	Ink nozzles are clogged.	See Clearing Clogged Ink Nozzles on page 68.
Printed barcode cannot be scanned	The media is not suitable for use in this printer.	Replace the media. See Choosing Label Media on page 12.
	The barcode is too small.	Adjust the size of the barcode.
	Ink nozzles are clogged and the barcode did not print properly.	See Clearing Clogged Ink Nozzles on page 68.
Ink is smudged on the labels	The media is not suitable for use in this printer.	Replace the media. See Choosing Label Media on page 12.
	Accumulated ink in the print zone.	<ol style="list-style-type: none"> 1. Open the clamshell and inspect the print zone (Figure 13). 2. Lightly moisten a lint-free cloth with de-ionized water and gently clean off any ink from the print zone and printhead. 3. Close the clamshell.
	The media is curled and touching the printhead.	<ol style="list-style-type: none"> 1. Replace the media. See Choosing Label Media on page 12. 2. If the problem persists, contact Technical Support.
	The media is curled by the unwinder when the printer is idle for a period of time.	<ol style="list-style-type: none"> 1. On the EWS Advanced Settings page, set the printer to retract the media when it is idle for more than 10 minutes. 2. If the problem persists, contact Technical Support.
	The service station needs to be replaced.	See Replacing the Service Station on page 51.
	Too much ink is laid (large areas of color in the image).	Adjust the amount of ink by adjusting the color settings for the image in Printing Preferences (Color Adjustment tab) .

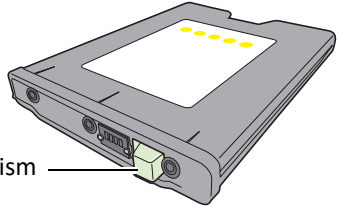
Problem	Possible Cause	Solution
Mixed or muddy colors	The printhead is dirty.	<ol style="list-style-type: none"> 1. Run Extended cleaning cycle from the control panel (⚙️ (Config) → MAINTENANCE → CLEAN → Extended). If print quality shows some improvement, repeat Extended cleaning until the print quality is satisfactory. 2. If print quality does not improve, open the clamshell and check for patches of wet ink on the printhead. 3. Use a lint-free cloth to absorb the ink. Avoid touching the neighboring nozzles. 4. Check the print quality. Run Extended cleaning cycle if necessary.
	Color ink cartridges are dirty.	<ol style="list-style-type: none"> 1. Remove the yellow (Y) ink cartridge from the printer. 2. Check the color of the ink through the ink level prism. <div style="text-align: center;">  <p>ink level prism</p> </div> <p>If the ink color is very dark (black) instead of yellow or iodine, replace all three color ink cartridges.</p>
Position of printed image drifts vertically	Top of Form position needs adjustment.	Adjust the Top of Form offset from the printer driver. See Adjust Alignment for Printing on page 21.
	The media is not loaded properly.	Reload the media.
	The media is not suitable for use in this printer.	Replace the media. See Choosing Label Media on page 12.
	The printer is unable to correctly detect the inter-label gap or black mark.	Adjust the sensitivity of the sensors. See Adjusting Sensor Sensitivity on page 70.

Problem	Possible Cause	Solution
Mis-registration or labels are skipped	Media settings do not match the media loaded in the printer.	Make sure the settings are correct for the media (e.g. media size and orientation).
	The media does not meet the specifications.	See Choosing Label Media on page 12 for the media specifications.
	The printer is unable to correctly detect the inter-label gap or black mark.	<ol style="list-style-type: none"> 1. Clean the sensors. See Cleaning the Sensors on page 46. 2. If the problem persists, adjust the sensitivity of the sensors. See Adjusting Sensor Sensitivity on page 70.
Labels are skipped when printing Roll to Roll on media with black mark	The printer is unable to correctly detect the inter-label black mark.	Adjust the media size in the printer driver: reduce the height by 0.1" (3 mm).

Other Printing Problems

Problem	Possible Cause	Solution
Printer feeds media without printing and then displays Wrong media on the LCD.	Media settings do not match the media loaded in the printer.	Make sure the Media Layout setting (gap, black mark, or continuous) in the printer driver matches the media used.
	The media does not meet the specifications.	See Choosing Label Media on page 12 for the media specifications.
	The printer is unable to correctly detect the inter-label gap or black mark.	<ol style="list-style-type: none"> 1. Clean the sensors. See Cleaning the Sensors on page 46. 2. If the problem persists, adjust the sensitivity of the sensors. See Adjusting Sensor Sensitivity on page 70.
Labels are not cut.	The exit sensor needs cleaning.	Clean the exit sensor. See Cleaning the Sensors on page 46.
Changes made using the control panel did not take effect.	The changes were not saved properly due to user or hardware error.	<ol style="list-style-type: none"> 1. Try changing the parameter again. 2. If the problem persists, reset the printer.¹ Try changing the parameter again. 3. If the problem persists, contact Technical Support.
The LCD is missing characters or parts of characters	The LCD may be damaged.	The LCD may need to be replaced. Contact Technical Support.
Nothing is displayed on the LCD and the printer freezes.	Internal electronic or firmware failure.	Contact Technical Support.
A white band appears at the TOF when printing in Sheet Per Cut and Print and Present mode with continuous media	The continuous media gap is set to a non-zero value	Make sure the continuous media gap in the EWS is set to zero.

1. Requires security Level 2 (administrator).

Clearing a Media Jam

1. Open the media cover.
2. Cut off the jammed media from the media roll.
3. [Open the clamshell](#) to its highest position.
4. Remove the jammed media from inside the printer.
5. [Close the clamshell](#) and top cover.
6. Reload the media.

Clearing Clogged Ink Nozzles

Long stripes of missing print or vertical light streaks on several labels may be an indication of clogged ink nozzles. Follow the procedure below to clear the ink nozzles.

After each step, print and check the print quality. Proceed to the next step only if the problem persists.

1. [Open the clamshell](#) and inspect the print zone (the area below the clamshell as shown in [Figure 13](#)). Vacuum any dust or debris from the area.

NOTE: Do **NOT** clean the printhead at this point.

Figure 13 Print zone

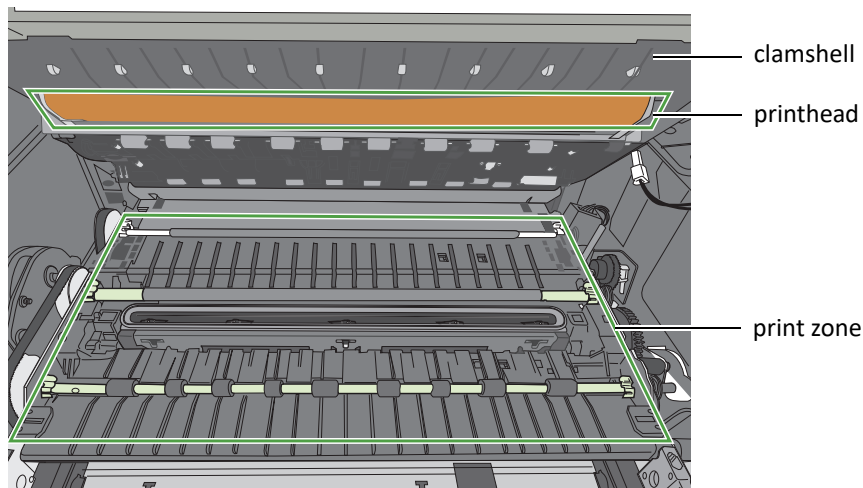

2. From the control panel, run Normal printhead cleaning.
( (Config) → MAINTENANCE → CLEAN → Normal)
 - If print quality shows some improvement, repeat Normal cleaning until the print quality is satisfactory.
 - If print quality does not improve, continue with [step 3](#).
3. Run the Extended cleaning cycle from the control panel.
 - If print quality shows some improvement, repeat Extended cleaning until the print quality is satisfactory.
 - If print quality does not improve, continue with [step 4](#).
4. Run the Extreme cleaning cycle from the control panel.
 - If print quality shows some improvement, repeat Extended cleaning until the print quality is satisfactory.
 - If print quality does not improve, continue with [step 5](#).
5. [Open the clamshell](#) and inspect the printhead. Lightly moisten a lint-free cloth with de-ionized water and gently clean off any ink. If no ink is visible, gently wipe the ink nozzles from one side to the other.
6. Change the printhead.
7. Contact Technical Support.

Adjusting Sensor Sensitivity

Adjust the sensor sensitivity if you encounter the following problems:

- The printer keeps feeding media and does not print. This may be because the printer is unable to detect the gap or black mark between labels and the sensor sensitivity needs to be increased.
- The printer does not position the media correctly for printing because it detects a “false” gap or mark. In this case the sensor sensitivity needs to be decreased.

Generally sensor sensitivity may need to be increased when the liner is thicker and decreased when the liner is thinner.

The sensor settings require security Level 1 (supervisor) or higher. Select the security level before you proceed (see [Selecting the Security Level](#) on page 11).

1. On the control panel, select  (Config) → SENSOR → TRANSMISSIVE (for inter-label gap) or REFLECTIVE (for black mark).
2. Set the sensitivity level.

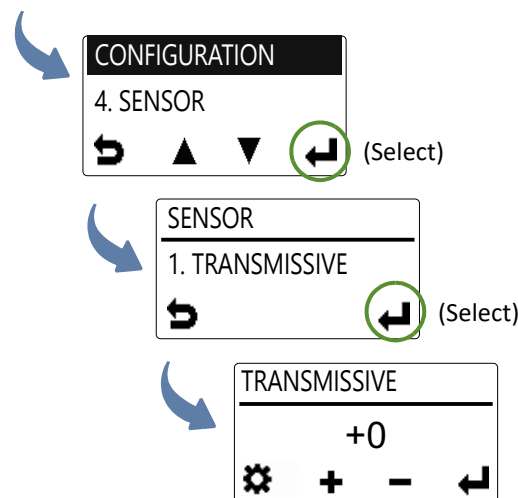
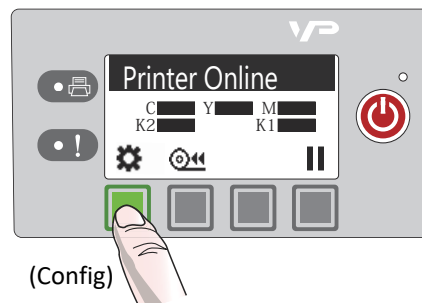

3. Press  to return to the main menu.

Try printing again. If the problem persists after repeated adjustments, the media is not compatible with the printer.

Appendix

System Requirements	72
Additional Networking Information	74
Config Options on the Control Panel	75
Printer Interface (GPIO) Specifications	79
Regulatory Information	81
Worldwide VIPColor Technologies Contacts	84

System Requirements

The computer used to print must meet the minimum requirements listed below.

Specifications	
Processor	Intel® Core™2 and above
Operating system	Supported operating systems with the latest updates: <ul style="list-style-type: none">• Windows 10 (32- and 64-bit)• Windows 8 (32- and 64-bit)• Windows 7 (32- and 64-bit) with Service Pack 1• Windows Server 2008 R2 (32- and 64-bit) with Service Pack 1• Windows Server 2003 R2 (32- and 64-bit) with Service Pack 2
Software	<ul style="list-style-type: none">• .NET Framework 3.5
Memory	<ul style="list-style-type: none">• Minimum: 2 GB
Available disk space	Minimum: 1 GB
Web browser	<ul style="list-style-type: none">• Internet Explorer• Google Chrome• Mozilla Firefox

.NET Framework Installation on Windows Server 2008 R2

After the .NET Framework is installed on Windows Server 2008 R2, follow the steps below to activate the features.

1. On the Windows **Start** menu, select **Administrative Tools > Server Manager**.
2. Click **Features** to view the status of installed features. Click **Add Features**.

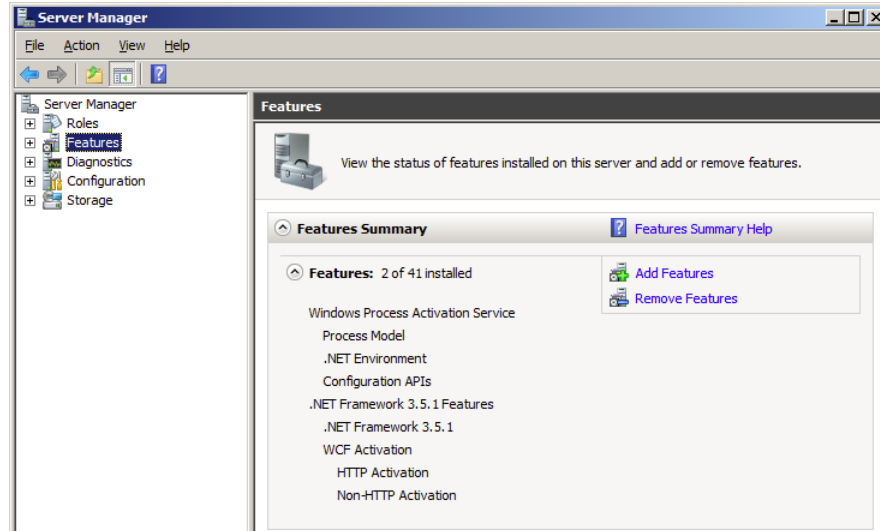

3. Select the **.NET Framework 3.5.1** entry and click **Next**.

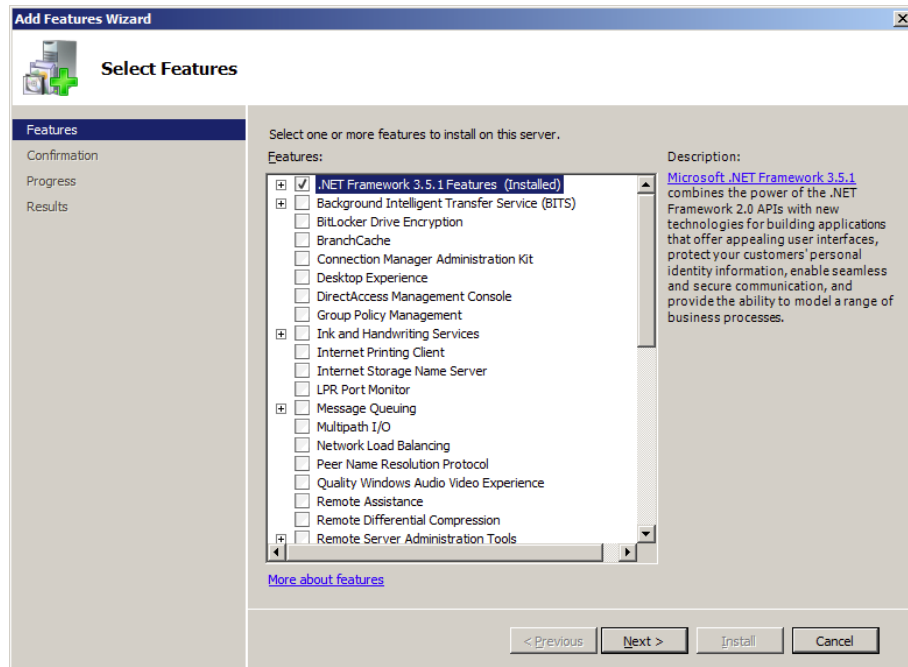





4. Confirm the installation by clicking **Install**.
5. When installation is complete, click **Close**. You may be prompted to restart the computer.

Additional Networking Information

If the Printer Has a Static IP Address

DHCP is enabled by default. If DHCP is not available and the printer is assigned a static IP address, set the static IP address from the control panel before installing the printer driver.

1. Press  (Config) on the control panel to access the configuration menus.
2. Level 2 security is required to change network settings (see [Selecting the Security Level](#) on page 11).
3. Scroll to the NETWORK menu to make the changes:

DHCP Setting	Set to Manual.
IP Settings	Enter the static IP settings for the printer. <ul style="list-style-type: none">• Static IP• Subnet Mask• Gateway• WINS Server <ol style="list-style-type: none">a. Press  and  to set each digit (0 to 9).b. Press  to move to the next digit.
4. Connect the printer to the network.
5. Insert the printer setup disc into the computer's disc drive to continue with the printer driver installation for a network printer.

If the Connection to the Printer Has Changed

If the printer has been set up using a USB connection and is later connected via the network (or vice versa), reinstall the printer driver.

1. Network – Connect the printer to the network.
USB – Do not connect the printer at this point. You will be prompted to do so during the driver setup.
2. Insert the printer setup disc into the computer's disc drive. Select the option **Add another printer**.
3. Follow the instructions to complete the installation.

Config Options on the Control Panel

On the control panel, press  (Config) to access the following menus and options. Some settings require security Level 1 or Level 2 (see [Selecting the Security Level](#) on page 11).

Menu/Option	Description
SETUP	
Language ¹	Select the display language for the printer control panel. Supported languages are: English, French, German, Spanish, Italian, Traditional Chinese, Simplified Chinese, and Japanese.
Reset ²	Restore the default factory settings.
List Setup	Print the key parameters of the printer which will fit neatly on a 4" x 4" label (with inter-label gap or continuous as specified in the EWS Diagnostics page).
Security	Display the current security level: <ul style="list-style-type: none">• Level 0 (operator) – The user can access all the functions needed to print, but cannot change printer parameters via the control panel.• Level 1 (supervisor) – The user can access certain printer parameters. A password is required to access this level.• Level 2 (administrator) – All parameters are enabled. A password is required to access this level. Passwords are set using the EWS (see Embedded Web Server (EWS) on page 27).
LCD Contrast ¹	Adjust the contrast of the text against the background (–3 to 3). Use + and – to increase or decrease the value.
LCD Brightness ¹	Adjust the brightness of the back light (–3 to 3). Use + and – to increase or decrease the value.
Date/Time ²	Set the printer clock (YYYY/MM/DD HH:MM:SS). <ol style="list-style-type: none">1. Press + and – to set each digit (0 to 9).2. Press ← to move to the next digit.
Unit ¹	Unit used for Adjust Offset, either inch or mm.
Label	Select either continuous, black mark or gap label stock for printing the PQ plot and configuration pages from the control panel.

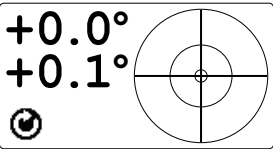
Menu/Option	Description
Page Cutting	<p>Select the printer default print mode. The available modes are</p> <ul style="list-style-type: none"> • Sheet per cut • Print and Present • Roll to Roll (Leave first label blank) • Roll to Roll (Print from first label) • Roll to Roll (Multiple job queue) <p>When the use printer setting is selected in the driver, the printer will use this mode.</p>
MAINTENANCE	
Print Test Page	<p>Print a test page. Load 4" x 4" or larger labels (with inter-label gap or continuous as specified in the EWS Diagnostics page).</p> <ul style="list-style-type: none"> • Barcodes: Print barcode test page. • PQ Plot: Print diagnostics test page.
PRINTHEAD	
Clean	<p>Clean the printhead. Always start with the Normal cleaning cycle and proceed to the next level only when print quality does not improve.</p> <ul style="list-style-type: none"> • Normal • Extended • Extreme
Replace	<p>Deprieme the printhead and release the printhead latch, allowing the user to change the printhead.</p>
SERVICE STATION²	
Cap Printhead	<p>Cap the printhead.</p>
Eject	<p>Eject the service station.</p>
SENSOR¹	
Transmissive	<p>Adjust the sensitivity of the transmissive gap sensor (-5 to 5). This sensor detects the inter-label gap or notch.</p>
Reflective	<p>Adjust the sensitivity of the reflective gap sensor (-5 to 5). This sensor detects the inter-label black mark.</p>
Level	<p>Detect and display the tilt angle of the printer.</p> <p>The print engine needs to be kept within two degrees from the horizontal plane in both the X and Y axes, otherwise ink flow to the printhead will be disrupted. Use this option to help you adjust the printer's tilt angle within ± 2 degrees from horizontal.</p> <div style="text-align: center;">  </div>

Menu/Option	Description
-------------	-------------

EXT SIGNAL PRINT¹	
-------------------------------------	--

By I/O	When this option is selected, the printer receives the print job but will not print until it receives a signal from an external device. See Printer Interface (GPIO) Specifications on page 79.
--------	--

ADJUST OFFSET¹	
----------------------------------	--

Use these options for [borderless printing](#) only.

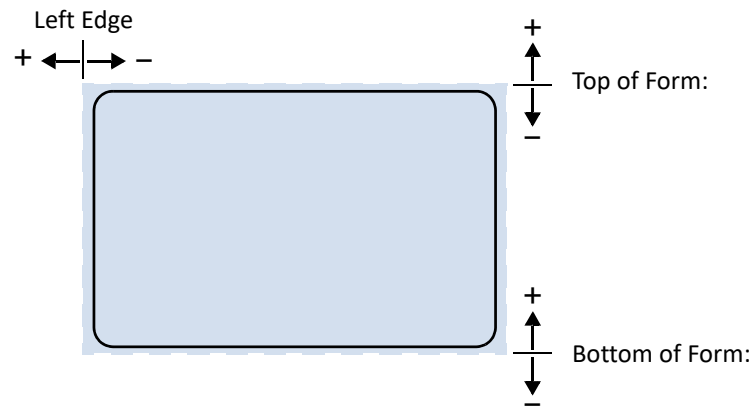

Top of Form	Adjust the starting line of the image.
Bottom of Form	Adjust the ending line of the image.
Left Edge	Adjust the print position horizontally.

Cutter Offset	Adjust the position of the cutter. A positive value adjusts the cut away from the top of the label while a negative value moves it nearer.
---------------	---

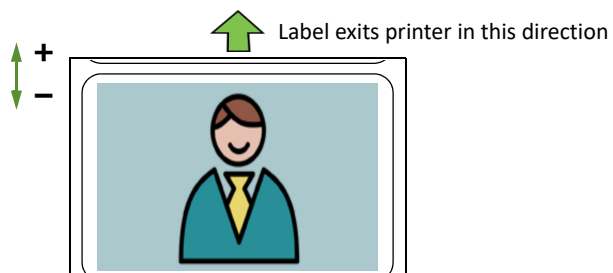

Menu/Option	Description
NETWORK	
List Network	Print the network setup parameters which will fit neatly on a 4" x 4" label (with inter-label gap or continuous as specified in the EWS Diagnostics page).
DHCP Setting ²	Set the IP settings on the printer. <ul style="list-style-type: none"> • Automatic: Set DHCP server to automatic. • Manual: Disable DHCP server or allow user to set a static IP.
IP Settings ²	Enter the static IP settings for the printer. <ul style="list-style-type: none"> • Static IP • Subnet Mask • Gateway • WINS Server <ol style="list-style-type: none"> 1. Press + and - to set each digit (0 to 9). 2. Press ← to move to the next digit.

1. Requires security Level 1 (supervisor) or higher.
2. Requires security Level 2 (administrator).

Printer Interface (GPIO) Specifications

The Printer Electrical Signal Interface and Protocol is developed to coordinate the printing of labels with an external process in a production workflow. Using this protocol, the printer (Device A) receives a print job but will not print until it receives a signal from an external device (Device B).

The following scenario illustrates how this could be used:

1. A box on a conveyor arrives at a workstation. A barcode is read and triggers a message to a computer.
2. The computer sends a print job (probably with some variable data) to the printer.
3. The box reaches the next station on the conveyor and triggers a signal (e.g. by a footswitch or automatically by a sensor). The printer starts printing when the signal is received.

The electrical signal to initiate printing is received at the printer's GPIO port. The handshaking protocol is as follows:

- The printer signals it is ready to print by pulling up the Print Job Ready signal from low to high.
- Device B signals it is ready by pulling up the Ready signal. This must remain high for at least 50 ms. When the Ready signal is pulled down while the printer is printing, the printer will pause and behave exactly the same way as if the user presses the Pause button on the control panel. The printer remains in Pause mode until the Ready signal is pulled up again for at least 50ms.
- The printer prints and pulls down the signal when printing is completed.
- No printing occurs whenever the Printer Error signal is pulled low.

Figure 14 Timing Diagram

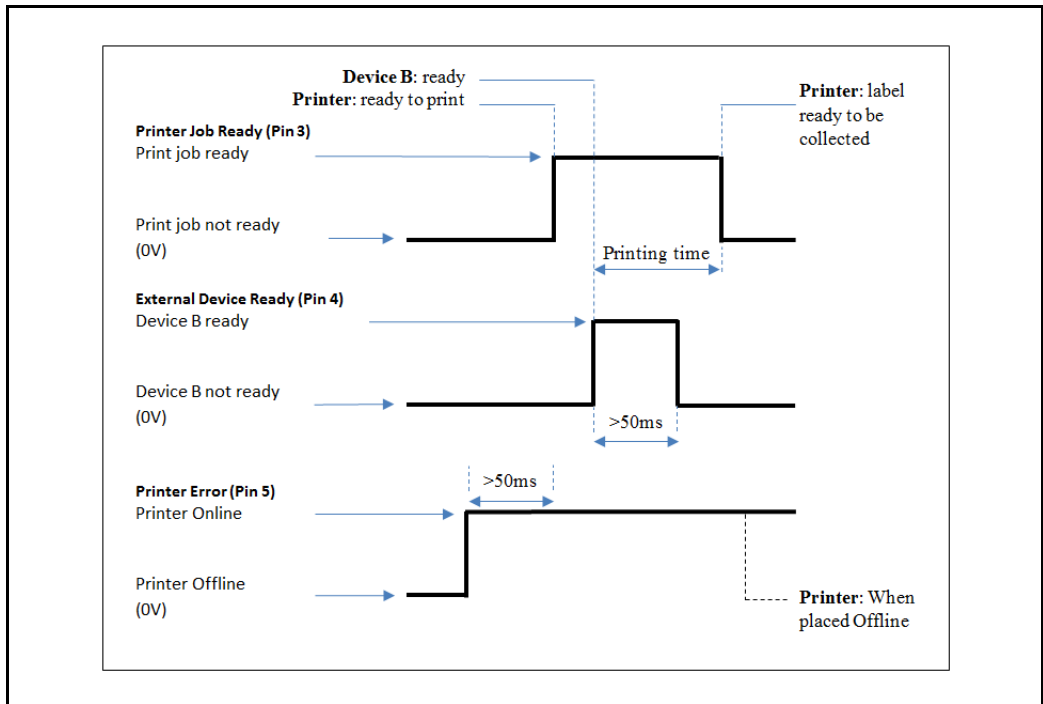

Table 13 GPIO Pin Assignment (D-sub 9-pin Connector)

Pin	Signal Description
1	HIGH (3.3 V)
2	ADC 5
3	Print job ready (output) (GPIO A25)
4	External device ready (input) (GPIO D04)
5	Printer error (output) (GPIO D08)
6	LOW (0 V)
7	NC
8	NC
9	NC

Regulatory Information

FCC Statement

NOTE: This equipment has been tested and found to comply with the limits for a Class A digital device, pursuant to Part 15 of the FCC Rules. These limits are designed to provide reasonable protection against harmful interference when the equipment is operated in a commercial environment. This equipment generates, uses, and can radiate radio frequency energy and, if not installed and used in accordance with the instruction manual, may cause harmful interference to radio communications. Operation of this equipment in a residential area is likely to cause harmful interference in which case the user will be required to correct the interference at their own expense.

NOTE: Any changes or modifications to this equipment which are not expressly approved by the manufacturer could void the user's authority to operate this equipment.

CE Conformity

For customers in Europe



The CE mark indicates that this product complies with the European requirements for safety, health, environment and customer protection.

This product complies with following European directives: Low Voltage Directive 2006/95/EC, EMC Directive 2004/108/EC, WEEE Directive 2002/96/EC and RoHS Directive 2011/65/EU.

Waste Electrical and Electronic Equipment Directive



This symbol on the product or on its packaging indicates that this product should be separately disposed of, and not together with other unsorted municipal household waste. Instead, it is your responsibility to dispose of your waste equipment by handing it over to a designated collection point for the recycling of waste electrical and electronic equipment.

The separate collection and recycling of waste equipment at the time of disposal will help to conserve natural resources and ensure that it is recycled in a manner that protects human health and the environment, through controlled treatment of possible hazardous substances that may exist. For more information about where you can drop off equipment for recycling, please contact your local city office, your household waste disposal service or the dealer where you purchased the product.



声明

此为 A 级产品，在生活环境中该产品可能会造成无线电干扰。在这种情况下，可能需要用户对其干扰采取切实可行的措施。



警告使用者

這是甲類的資訊產品，在居住的環境中使用時可能會造成射頻干擾：在這種情況下，使用者會被要求採取某些適當的對策。

VP600 产品：有毒和危險物品表

按照电子信息产品中国污染控制管理方法的要求（依据 SJ/T11363-2006 标准）

部件名称	有毒和危險物品					
	铅 (Pb)	水银 (Hg)	镉 (Cd)	六价铬 (Cr+6)	多溴化苯 (PBB)	多溴化二苯醚 (PBDE)
外部表面，隔板以及底盘	O	O	O	O	O	O
PCAs 以及电气元件	X	O	O	O	O	O
电缆线材	X	O	O	O	O	O
光学系统	O	O	O	O	O	O
转轴	O	O	O	O	O	O
液压 / 气压系统	O	O	O	O	O	O
纸处理系统	X	O	O	O	O	O
耗材	O	O	O	O	O	O

备注

O: 表示该项目中涉及的所有物料，其包含的有害物质的含量低于 SJ/T11363-2006 标准的限制要求。

X: 表示该项目中涉及的所有物料中至少有一中，其包含的有害物质的含量高于 SJ/T11363-2006 标准的限制要求。

注意：供参考的环境保护数据是在产品要求的正常使用环境中测试获得，例如温度和湿度等。

VP600 限用物質含有情況標示聲明書

單元 Unit	限用物質及其化學符號 Restricted substances and chemical symbols					
	鉛 Lead (Pb)	汞 Mercury (Hg)	鎘 Cadmium (Cd)	六價鉻 Hexavalent chromium (Cr(VI))	多溴聯苯 Polybrominate d biphenyls (PBB)	多溴二苯醚 Polybrominated diphenylethers (PBDE)
外殼·隔板以及 底盤	○	○	○	○	○	○
PCAs 以及電氣 元件	-	○	○	○	○	○
電纜線材	-	○	○	○	○	○
光學系統	○	○	○	○	○	○
轉輓和滾筒	○	○	○	○	○	○
液壓 / 氣壓系統	○	○	○	○	○	○
紙處理系統	-	○	○	○	○	○
耗材	○	○	○	○	○	○

備考 1: “超出 0.1wt%” 及 “超出 0.01 wt%” 係指限用物質之百分比含量超出百分比含量基準值。

備考 2: “○” 係指該項限用物質之百分比含量未超出百分比含量基準值。

備考 3: “-” 係指該項限用物質為排除項目。

Note 1: “Exceeding 0.1 wt%” and “exceeding 0.01 wt%” indicate that the percentage content of the restricted substance exceeds the reference percentage value of presence condition.

Note 2: “○” indicates that the percentage content of the restricted substance does not exceed the percentage of reference value of presence.

Note 3: “-” indicates that the restricted substance corresponds to the exemption.

Worldwide VIPColor Technologies Contacts

VIPColor Technologies USA, Inc.
1621 Barber Lane
Milpitas CA 95035, USA
Phone: +1 510 744 3770
www.vipcolor.com/us

Venture Electronics Spain S.L.
C Pagesia, 22-24
08191 Rubí
Barcelona, Spain
Phone: +34 93 588 3018
www.vipcoloreurope.com/uk

VIPColor Technologies Pte Ltd
5006 Ang Mo Kio Avenue 5
#05-01/12 TECHplace II
Singapore 569876
Singapore
Phone: +65 6482 1755
www.vipcolor.com/ap